

2011

Approaches to Arc Flash Hazard Mitigation in 600 Volt Power Systems

Curtis Thomas Latzo

University of South Florida, curtis@latzo.com

Follow this and additional works at: <http://scholarcommons.usf.edu/etd>

 Part of the [American Studies Commons](#), and the [Electrical and Computer Engineering Commons](#)

Scholar Commons Citation

Latzo, Curtis Thomas, "Approaches to Arc Flash Hazard Mitigation in 600 Volt Power Systems" (2011). *Graduate Theses and Dissertations*.

<http://scholarcommons.usf.edu/etd/3198>

This Dissertation is brought to you for free and open access by the Graduate School at Scholar Commons. It has been accepted for inclusion in Graduate Theses and Dissertations by an authorized administrator of Scholar Commons. For more information, please contact scholarcommons@usf.edu.

Approaches to Arc Flash Hazard Mitigation in 600 Volt Power Systems

by

Curtis T. Latzo

A dissertation submitted in partial fulfillment
of the requirements for the degree of
Doctor of Philosophy
Department of Electrical Engineering
College of Engineering
University of South Florida

Major Professor: Kenneth Buckle, Ph.D.
Ralph E. Fehr, Ph.D.
Paris H. Wiley, Ph.D.
Paul Schnitzler, Ph.D.
Thomas L. Crisman, Ph.D.

Date of Approval:
November 3, 2011

Keywords: Fault Current Analysis, Circuit Breaker Coordination, Power System Protection, Molded Case Circuit Breaker, Low Voltage Power Circuit Breaker

Copyright © 2011, Curtis T. Latzo

ACKNOWLEDGMENTS

I would like to take this opportunity to thank my supervisor Dr. Kenneth Buckle for his valuable guidance and support throughout my doctoral program. I would like to thank my committee members, Dr. Ralph Fehr, Dr. Paris Wiley, Dr. Paul Schnitzler and Dr. Thomas Crisman for their generous advice and interest.

I would like to thank my friend and professional mentor George Lewis (Hank) Johnson. Without the input from Hank, this dissertation would not have been possible.

DEDICATION

This dissertation is dedicated to my wife, Tami, and my daughter, Lily, for giving me endless love and support and for inspiring me to complete this task.

Also, I would like to thank my parents, Ray and Rosemarie Latzo, for supporting me in countless ways and for giving me the greatest brothers and sister in the world - George, Steve and RaeAnn.

Additional thanks to all of my extended families of Latzo, Donatelli, Osust, Fiore, Ciaravino, and Bianco.

TABLE OF CONTENTS

LIST OF TABLES	iii
LIST OF FIGURES	iv
ABSTRACT	viii
1. INTRODUCTION	1
1.1 Overview of Electrical Safety	1
1.2 Importance of Arc Flash	4
1.3 Research Objectives	6
1.4 Contribution of the Dissertation	8
1.5 Outline of the Dissertation	8
2. POWER SYSTEM PROTECTION	11
2.1 Electrical System Abnormalities	11
2.2 Electrical System Overloads	12
2.3 Electrical System Faults	13
2.4 Circuit Breakers	15
2.5 Circuit Breaker Testing	21
2.6 Fuses	22
3. ELECTRICAL POWER SYSTEM STUDIES	25
3.1 Fault Current Analysis	25
3.2 Protective Device Selective Coordination	35
3.3 Arc Flash Hazard Analysis	44
3.4 Arc Flash Hazard Risk Categories	54
4. EXISTING ARC FLASH HAZARD MITIGATION TECHNIQUES	57
4.1 Changing Work Methods and Procedures	57
4.2 Temporarily Modifying Existing Protective Device Settings	58
4.3 Increasing the Working Distance	60
4.4 Arc Flash Resistant Switchgear	61
4.5 Optical Light Sensor Technology	62
4.6 Allowing a Lack of Circuit Breaker Selectivity	68
5. IMPACT OF ARC FLASH ANALYSIS	70
5.1 Free Standing Ambulatory Surgery Center	70
5.2 Heart Catheterization Center	79
5.3 Metal Container Manufacturer	88

6. IMPLEMENTATION OF DESIGN METHODS FOR ARC FLASH MITIGATION	99
6.1 When Applying the National Electric Code, Article 230, Part VI, Always Specify a Single Main Circuit Breaker for Building Shutdown.....	100
6.2 At the Electrical Service Entrance the Design Shall Specify Low Voltage Power Circuit Breakers Instead of Fused Disconnect Switches.....	107
6.3 Specify Adjustable Low Voltage Power Circuit Breakers for Protection of Step-Down Transformers Rated above 125kVA.....	111
6.4 Step-Down Transformers Larger than 125kVA Shall Be Replaced with a Design Having Two Smaller Transformers.....	121
7. CONCLUSIONS AND FUTURE WORK.....	126
7.1 Conclusions.....	126
7.2 Further Work.....	129
REFERENCES	130

LIST OF TABLES

Table 1.1: Reaction of Human Body to Electric Current.....	2
Table 2.1: Test X/R Ratios for Protective Devices.....	21
Table 3.1: Simulation Results for 1500kVA Transformer with Z=5%.....	30
Table 3.2: Test X/R Ratios for Protective Devices.....	34
Table 3.3: Classes of Equipment and Typical Bus Gaps.....	46
Table 3.4: Distance x Factors	48
Table 3.5: Classes of Equipment and Typical Working Distances.....	49
Table 3.6: Hazard Risk Categories and PPE Characteristics.....	55
Table 5.1: Equipment Evaluation Table for Surgery Center	72
Table 5.2: Equipment Evaluation Table for Heart Catheterization Lab.....	81
Table 5.3: Equipment Evaluation Table for Bus Duct Feeder	91
Table 7.1: Before and After Arc Flash Hazard	129

LIST OF FIGURES

Figure 2.1: Fault Current Waveform Profile.....	14
Figure 2.2: TCC Curve for 480 volt, 100 amp MCCB	17
Figure 2.3: TCC Curve for 480 volt, 100 amp MCCB with Low and High Settings	18
Figure 2.4: TCC Curve Showing 480 volt, 100 ampere LVPCB	19
Figure 2.5: TCC Curve for 480 volt, 100 ampere LVPCB with LSI Settings	20
Figure 2.6: TCC for 480 volt, 100 ampere Fuse	24
Figure 3.1: Series R-L Circuit.....	26
Figure 3.2: One-Line Diagram of Utility Serving Main SWBD	28
Figure 3.3: Utility Contribution One-Lines	30
Figure 3.4: Fault Current Waveform	31
Figure 3.5: Peak Asymmetrical Current versus X/R Ratio.....	33
Figure 3.6: Partial One-Line Diagram Showing Fault Current Values and X/R Ratios....	35
Figure 3.7: One-Line Diagram of a Two Motor Electrical System	37
Figure 3.8: Time Current Curves for a Circuit Breaker and a Fuse.....	38
Figure 3.9: Time Current Curves for a Selectively Coordinated System	39
Figure 3.10: Time Current Curves with a Lack of Selective Coordination	40
Figure 3.11: Time Current Curves for Thermal Magnetic Breakers	42
Figure 3.12: Time Current Curves for LSI Circuit Breakers	43
Figure 3.13: Circuit Breaker TCC Interrupting Arcing Current	51
Figure 3.14: Circuit Breaker TCC Interrupting Arcing Currents	52

Figure 3.15: Partial One-Line Showing Panel-B Incident Energy	53
Figure 3.16: Partial One-Line Showing Panel-B Incident Energy and Hazard Risk Category	56
Figure 4.1: Incident Energy Before and After Temporary Setting of Breaker CB- Main.....	59
Figure 4.2: Incident Energy Before and After Increasing Working Distance	61
Figure 4.3: Typical Fiber Optic Routing in Switchgear	64
Figure 4.4: Arc Detection Relay Block Diagram.....	65
Figure 4.5: Arc Detection Relay Operating Times	66
Figure 4.6: Incident Energy Levels With and Without Arc Flash Relay.....	67
Figure 4.7: Single Fiber Loop Layout.....	68
Figure 5.1: One-Line Diagram for Surgery Center.....	71
Figure 5.2: TCC Curve for Surgery Center	73
Figure 5.3: Time Current Curve for Arcing Current at PNL-N1	74
Figure 5.4: Time Current Curve for Arcing Current at MDP	75
Figure 5.5: One-Line Diagram for Surgery Center with Added Main Fuse.....	77
Figure 5.6: TCC for Arcing Current at MDP with Added Fuse	78
Figure 5.7: One-Line Diagram for Heart Catheterization Lab	80
Figure 5.8: TCC Curve for Heart Catheterization Lab	82
Figure 5.9: Time Current Curve for Arcing Current at Panel H1	83
Figure 5.10: Time Current Curve for Arcing Current at Panel LDP	84
Figure 5.11: One-Line Diagram for Surgery Center with Added Main Breaker.....	86
Figure 5.12: TCC for Arcing Current at Panel LDP with LSI Breaker	87
Figure 5.13: TCC for Heart Catheterization Lab after Breaker Change.....	88

Figure 5.14: Partial One-Line Diagram for Bus Duct Feeder.....	90
Figure 5.15: TCC for PD-Bus B and PD-Bus B1	92
Figure 5.16: Time Current Curve for Arcing Current at Bus-B	93
Figure 5.17: Time Current Curve for Arcing Current at Bus-B1	94
Figure 5.18: Partial One-Line Diagram after Implementation of Dis-Coordinated Settings.....	95
Figure 5.19: TCC for Arcing Current at Bus-B after Breaker Adjustment	96
Figure 5.20: TCC for Arcing Current at Bus-B1 after Breaker Adjustment	97
Figure 6.1: Partial One-Line Diagram with 6-Hand Rule in Use	101
Figure 6.2: TCC Showing Arc Flash Exposure for Six-Hand Rule.....	103
Figure 6.3: Partial One-Line Diagram with Main Breaker Installed	105
Figure 6.4: TCC with Main Breaker Installed	106
Figure 6.5: One-Line Diagram Showing Main Fused Disconnect	107
Figure 6.6: TCC for Main Fused Disconnect.....	108
Figure 6.7: Partial One-Line Diagram for Service Entrance with LSI Main Breaker	109
Figure 6.8: TCC for Service Entrance with LSI Main Breaker	110
Figure 6.9: Partial One-Line Diagram Showing Arc Flash Increase across 225kVA	112
Figure 6.10: TCC Showing Thermal-Mag Breaker and Arcing Current at Primary of XF-1	114
Figure 6.11: TCC Showing Thermal-Mag Breaker and Arcing Current at Secondary of XF-1	115
Figure 6.12: Partial One-Line Diagram Showing Arc Flash Mitigation across 225kVA.....	117
Figure 6.13: TCC Showing LSI Breaker and Arcing Current at Primary of XF-1.....	119
Figure 6.14: TCC Showing LSI Breaker and Arcing Current at Secondary of XF-1.....	120

Figure 6.15: Partial One-Line Diagram with 225kVA Step-Down Transformer	121
Figure 6.16: TCC Showing Arc Flash Hazard at Panel L1.....	122
Figure 6.17: Partial One-Line Diagram Showing Two 112.5kVA Transformers	123
Figure 6.18: TCC Showing Arc Flash Hazard at Panel L2.....	124

ABSTRACT

Federal regulations have recognized that arc flash hazards are a critical source of potential injury. As a consequence, in order to work on some electrical equipment, the energy source must be completely shut-down. However, power distribution systems in mission critical facilities such as hospitals and data centers must sometimes remain energized while being maintained. In recent years the Arc Flash Hazard Analysis has emerged as a power system tool that informs the qualified technician of the incident energy at the equipment to be maintained and recommends the proper protective equipment to wear. Due to codes, standards and historically acceptable design methods, the Arc Flash Hazard is often higher and more dangerous than necessary.

This dissertation presents detailed methodology and proposes alternative strategies to be implemented at the design stage of 600 volt facility power distribution systems which will decrease the Arc Flash Hazard Exposure when compared to widely used code acceptable design strategies. Software models have been developed for different locations throughout a power system. These software model simulations will analyze the Arc Flash Hazard in a system designed with typical mainstream code acceptable methods. The model will be changed to show implementation of arc flash mitigation techniques at the system design level. The computer simulations after the mitigation techniques will show significant lowering of the Arc Flash Hazard Exposure.

1. INTRODUCTION

The first power systems in the early 1880s were created to provide a source of electricity for lighting. Thomas Edison's invention of the light bulb and the direct current electrical system to power it was the beginning of the electrical generation industry. Edison not only invented the light bulb, but also the distribution network, switches, protective fuses, and insulating materials to make it all work. This was soon followed by the invention of the electric motor in the late 1880s, which rapidly increased the demand on the power system. Just a few years later, Nikola Tesla and George Westinghouse would prove that their alternating current system was technically superior, since it was able to be transformed to different voltages for transmission [1]. Soon after these electric systems came on-line, the first electrical shock from a commercial power system occurred. This led to the beginning of development for today's safety codes and standards.

1.1 Overview of Electrical Safety

People quickly learned that electric shock was not the only hazard created by power systems. When equipment was not installed properly, a fire could erupt creating even more danger. The novice contractors knew very little about electrical installations making the likelihood of a disaster high. The need for some form of guidance in the practice of electrical installation was evident. This was the beginning of what is now

known as the *NFPA 70: National Electric Code (NEC)*, first published in 1897 [1]. This code is used regularly for electrical system design standards and installation methods. The plan review process and electrical inspections performed by building departments are also based on the NEC.

Even with the proper electrical design and installation, accidents could possibly occur when people make contact with energized equipment. Throughout the years, people learned that electrical shock could cause serious injury and death. However, there was very little knowledge on the effects of electrical shock on humans. It was not until 1956 that Charles Dalziel began performing shock experiments on animals and humans. His quest to find out how much electrical current was needed to stop a person from breathing or to stop a heart from working led to the information in Table 1.1 [2]. This work alerted humans to the risk of small amounts of electricity and increased safety awareness.

Table 1.1 Reaction of Human Body to Electric Current

AC Current	Effect of Current
0.7 – 1 mA	Perception Threshold (tingling sensation)
1.2 – 1.8 mA	Slight Shock – not painful
6 – 9 mA	Shock – painful (no loss of muscle control)
15 – 23 mA	Shock – severe (muscle control loss, breathing difficulty)
0.1 A	Possible ventricular fibrillation (3-second shock)
0.2 A	Possible ventricular fibrillation (1-second shock)
0.5 A	Heart muscle activity ceases
1.5 A	Tissue and organ burn

The industrial revolution from 1950 to 1970 created enormous growth in the United States. With this expansion came many workplaces with little concern for employee safety. Based on Occupational Safety and Health Administration statistics from 1970, there were 14,000 worker deaths that year from job related accidents [3]. Close to 2.5 million workers would become disabled and 300,000 individuals would contract an occupational disease [3]. This prompted Congress to pass the Occupational Safety and Health Act of 1970, leading to the formation of the Occupational Safety and Health Administration (OSHA).

OSHA covers all employers and employees in the United States of America, with a few exceptions for self-employed people and family run farms. Among other things, OSHA, Title 29, Code of Federal Regulations addresses electrical safety. Typical of OSHA standards, this section gives a general requirement and not specific details on how to achieve the requirement. Initially, OSHA selected language from the NEC as a basis for the electrical regulations [1]. However, the NEC is aimed at design and installation practices and does not cover worker safety during equipment use. Therefore, a new code aimed at everyday worker safety on the job was needed.

In 1976, the NFPA formed a committee at the request of OSHA to develop a new standard for electrical safety in the workplace. This resulted in *NFPA 70E: Standard for Electrical Safety in the Workplace*. The purpose of this standard is to provide a safe workplace for employees with regard to electrical safety. This gave OSHA a reference for electrical safety so employers could have a standard to follow.

NFPA 70E, was the first standard responsible for instructing electrical maintenance personnel on how to work safely with regard to shock protection. This code

informed the worker of proper clothing, shoes, and rubber gloves. This code also gave guidelines for proper use of voltage measuring devices and insulated tools. Furthermore, NFPA 70E assigned given distances or boundaries from energized equipment that would give the workers a reference of where the clothing was to be worn. The electricians now had a strategy in place to protect themselves from electric shock.

1.2 Importance of Arc Flash

In time it became apparent that not all electrical accidents were due to electrical shock from making contact with energized devices. When an exposed energized conductor makes contact with the ground or another energized device, a small spark or a large explosion could ignite. This explosion, otherwise known as an arc flash, can have thermal energy that is dangerous from a distance of several feet away. One of the early papers addressing the arc flash was written in 1982 by Ralph Lee [4]. In this paper, Lee crossed the bridge between electrical shock from contact with energized devices, to thermal burn from the radiant heat output of electrical arcs. Lee's paper presented theoretical methods for evaluating incident energy of an arc in open air. Additionally, Lee's research explained the relationship between heat transfer from hotter to cooler objects and the importance of the distance between them. Lee's paper goes on to develop a relationship between heat transfer and distance with its effects on human skin tissue.

Acknowledging arc flash had several important consequences. First, electrical workers needed to protect themselves from the dangers of both shock hazards and arc flash thermal effects. Secondly, the workers needed to know what degree of potential electrical hazards they were being exposed to. Thirdly, workers would need to know the

proper protective clothing and equipment required to ensure their safety at a particular level of exposure.

In time, the focus of arc flash hazard research turned toward predicting and calculating the incident energy produced. In 1998, Doughty, Neal, and Floyd did extensive research on the measurement and calculation of arc flash [5]. Their research detailed a testing program completed to measure incident energy from 6-cycle arcs on 600 volt power systems. The testing led to algorithms for predicting incident energy based on available fault current and the distance from the source. These algorithms were shown to support Ralph Lee's research. However, this testing also showed an increase in incident energy when the source is in an enclosure with an open door versus a source in open air, such as an overhead conductor. This proved important because most arcs occur when a person is standing in front of an open electrical enclosure and the arc is confined in the panel-board or switchgear.

In 2000, the NFPA released a new version of NFPA 70E. This update recognized the existence of the "Arc Flash Hazard" and included a new protection strategy in addition to shock protection. There was now a section on Personal Protection Equipment (PPE) requirements and hazard risk tables. This standard identified specific electrical work activities and put them in five categories (0-4). Each category had a detailed clothing arc flash rating and additional equipment to be worn, such as hard hats and facemasks. However, this method of selecting protective equipment was based solely by task and not on actual knowledge of the arc flash hazard level at any location in the electrical system.

The findings detailed above, along with the focus of industry on electrical safety, led to the need for guidelines and standards addressing the arc flash. In 2002, The Institute of Electrical and Electronics Engineers published *Standard 1584 “IEEE Guide for Performing Arc-Flash Hazard Calculations”* [6]. This guide was a direct result of research conducted by the IEEE and was sponsored by large electrical corporations and manufacturers. The standard provided the first complete set of guidelines for calculating incident energy of the arc flash at the location of interest in a power distribution system. This was important because it provided a standardized way to calculate the arc flash hazard associated with working on energized equipment.

By utilizing these calculation methods, an engineer is able to predict the thermal exposure at any location in an electrical system. The workers now have a guideline for protection from electrical shock and arc flash hazard. This is important because the shock protection protective equipment is made from specific materials to keep a person isolated from touching the energized equipment. The arc flash hazard protective equipment is made of materials that are designed to protect the worker from getting burned from the thermal effects of the arc flash.

1.3 Research Objectives

New electrically critical facilities, including computer data centers and hospitals, are electrically designed and constructed to have a continuous energy source. This is accomplished by integrating the electrical utility with on-site generators and uninterruptible power supplies. This electrical equipment must be serviced and maintained, but de-energizing the devices is not an option. The application of arc flash

mitigation techniques after construction can lead to additional equipment and expenses. Furthermore, there can be situations where an extremely high arc flash hazard is unavoidable. Implementing design strategies as described in this paper can minimize the arc flash hazard exposure at many locations throughout the electrical distribution system.

This research focuses on the challenges of minimizing the arc flash hazard exposure to electricians working on energized electrical equipment in 600 volt and below power systems. Although the electrical systems analyzed in this dissertation are at 480 volts, the 600 volt rating is important to the applicable standards for the voltage class. This work looks at the electrical system design requirements that are currently acceptable by the NEC and how this can expose electrical workers to a high arc flash hazard. These systems will be modeled using an industrial grade software package, which implements arc flash hazard calculations per IEEE-1584. Recommended design changes that include NEC and NFPA 70E requirements will be implemented and the systems will be re-calculated to show significant decrease of the arc flash exposure.

It is the researcher's hypothesis that NEC acceptable design strategies can be altered to include NFPA 70E concerns, therefore minimizing Arc Flash Hazard exposure. This is specifically in the areas of:

1. When applying the National Electric Code, Article 230, Part VI, always specify a single main circuit breaker for building shutdown.
2. At the electrical service entrance the design shall specify enclosed low voltage power circuit breakers in place of fused disconnects.
3. Specify adjustable low voltage power circuit Breakers for protection of step-down transformers rated above 125kVA.

4. Step-Down Transformers larger than 125kVA shall be replaced with a design having two smaller kVA transformers.

1.4 Contribution of the Dissertation

The design techniques recommended in this dissertation are a result of 21 years of experience as a licensed professional engineer focusing on designing electrical systems and performing arc flash hazard studies. The outcome of this study can influence future design techniques that would consider NEC, NFPA 70E, and Arc-Flash hazard exposure. If the resulting information is transferred to a training environment for electrical system design engineers it can be implemented into their future projects. The implementation of these results can produce electrical systems with lower arc flash hazard at maintainable areas of a building electrical system.

1.5 Outline of the Dissertation

This dissertation consists of 6 chapters, with the first chapter introducing the development of electrical safety codes with regard to electrical shock and arc flash hazard. The history and development of the NEC, NFPA-70E, and IEEE-1584 are briefly discussed. The focus for conducting this research along with the hypothesis and goals are described.

Chapter 2 will present the basics of power system protection from a time versus current analysis. There will be discussion of electrical current overloads and short circuits. The principles of electrical circuit breaker devices and fuses will be described. The different types of circuit breakers and their specifications will be discussed.

Chapter 3 presents an overview of electrical power system studies for 480 volt power systems. The process of a fault current calculation will be conceptually described to show the purpose of the study, modeling approach, and the software implementation. The utility source and its contribution into the system will be presented. The protective device coordination will be shown and the circuit breaker options will be discussed. The arc flash hazard analysis will be presented and shown how it applies to 480 volt systems.

Chapter 4 will explore existing methods, techniques and devices aimed at mitigating the arc flash hazard exposure. These devices and techniques will be computer simulated to show the arc flash hazard before and after mitigation techniques are applied. The implemented equipment and techniques will show a decreased arc flash hazard incident energy and category.

Chapter 5 will present the impact of arc flash hazard analysis on existing mission critical facilities. The existing electrical systems will be described along with objectives for the arc flash hazard analysis. The study will be performed by using computer simulation software and the results discussed. Methods for mitigating the arc flash hazard will be recommended and the system will be reevaluated by the software to show a decrease in the arc flash hazard.

Chapter 6 will highlight design methods to help mitigate arc flash hazard exposure. Each case will show part of a 480 volt electrical system that is in compliance with the NEC and acceptable for an electrical building permit. The arc flash analysis will be performed on the system giving an incident energy level and hazard category. Recommendations to the system design will be made and a recalculation of the arc flash

hazard will be performed. The implemented design recommendations will show a decreased arc flash hazard incident energy and category.

Chapter 7 will discuss the conclusions and future work. The results of implementing the recommended design techniques will be reviewed. Guidelines for future work will be discussed.

2. POWER SYSTEM PROTECTION

In theory, the ideal electrical system receives power from the utility distribution system and performs exactly as the customer demands with no interruptions, voltage sags, or outages. This would allow for a system to be designed for amperage demand without having any concern about short term electrical transients. The practical use and maturation of an electrical system can involve many system abnormalities, such as overloads and short circuits. The response by the system under these transient conditions determines the functionality, viability, safety, and long term usefulness of the electrical distribution equipment. Power system protection is part of the design, planning and operation of an electrical system. Some of the main objectives of the protection system are to isolate short circuits and prevent equipment failure due to overload. This is accomplished by detecting electrical system abnormalities with the proper application of circuit breakers and fuses.

2.1 Electrical System Abnormalities

There are a multitude of electrical system abnormalities that can occur at any time. Some of these disturbances are voltage related and others are current based. The voltage related electrical system disturbances are classified as power quality issues and usually result in the alteration of the ideal sine wave. This is an important issue because newer generation load equipment, with microprocessor-based controls and power

electronic devices, is more sensitive to power quality variations than equipment used in the past [36]. The term power quality is an umbrella concept for a multitude of individual types of power system disturbances [36]. Some of these voltage based disturbances are interruptions, sags, swells, under-voltages, overvoltage, voltage imbalance, and harmonics. From a protection standpoint, these voltage disturbances are classified separately from current disturbances.

Although voltage and current disturbances can be related through causation, current disturbances are primarily defined by the presence of an overcurrent. The National Electrical Code defines an overcurrent as any current in excess of the rated current of equipment or the ampacity of a conductor. It may result from overload, short circuit, or ground fault [17]. Therefore, from a protection standpoint, the main objective is to avoid exposing the devices to overload conditions and isolate the equipment from faults and short circuits.

2.2 Electrical System Overloads

One of the main objectives for the electrical protection system is to prevent equipment failure caused by overload. Overload is defined by the National Electrical Code as the operation of equipment in excess of normal, full-load rating, or of a conductor in excess of rated ampacity that, when it persists for a sufficient length of time, would cause damage or dangerous overheating. A fault, such as a short circuit or ground fault, is not an overload [17]. Therefore, an overload occurs when the system is properly intact, but the use of the system is not per design. An example of overload is when two 1500 watt hair dryers are attached to receptacles on the same 120 volt, 20 amp circuit. In

this case, the 3000 watts equates to 25 amps thus overloading the 20 amp conductor and circuit breaker.

2.3 Electrical System Faults

A fault occurs when the use of the system is per design, but the system is not properly intact. Some causes of faults can include weather, insulation failure, wildlife, vehicle crashes, and vandalism. When this unintentional electrical path is created, the system creates undesirable current paths that must be accounted for. The result is a collapse in voltage and an extreme inrush of current toward the fault location.

During a fault, the current from all parts of the electrical system flow in the direction of the short circuit. This fault current level can range from 6.5kA amps at a 13.2kV substation, to near 100kA at a 480 volt paralleled system. Fault levels are known to decrease with distance from the source due to system impedance [38]. It is important to protect the system from adverse effects that can occur from large magnitude currents. Power system faults may be categorized as one of four types: single line-to-ground, line-to-line, double line-to-ground, and balanced three-phase [37]. Line-to-line faults are approximately 87% of three-phase fault currents. Line-to-ground faults can range from a few percent to possibly 125% of the three-phase value. In industrial systems, however, line-to-ground fault currents higher than the three-phase value are rare [49]. It is widely recognized that line-to-line faults in equipment or cables quickly escalate into three-phase faults [6]. In an industrial system, the three-phase fault condition is frequently the only one considered, since this type of fault generally results in maximum current [49]. All testing used in arc flash modeling was three-phase tested because three-phase arcs

produce the greatest possible arc-flash in ac equipment. Therefore, this project will focus only on three-phase balanced faults.

It is convenient to analyze fault current as an asymmetrical waveform consisting of a symmetrical AC wave superimposed on a DC current [12]. The resulting waveform is shown to have an original peak value several magnitudes above the pre-fault conditions and is asymmetrically shaped from the x-axis. The peak value occurring during the first half cycle of the fault is known as the Available Fault Current (AFC). This can be graphically represented as shown in Figure 2.1.

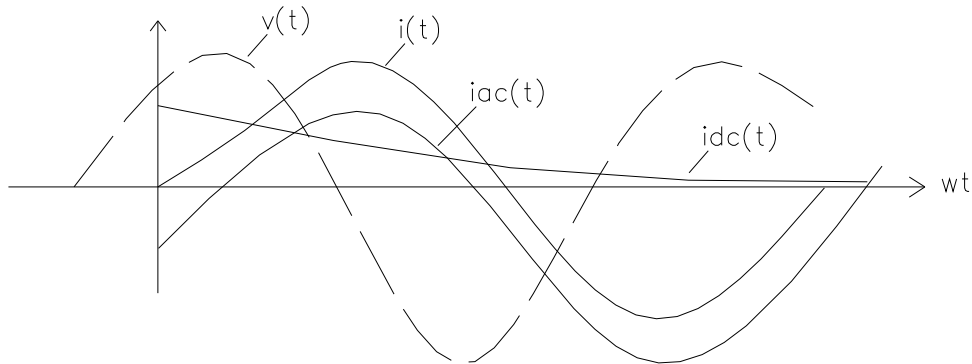

$v(t)$ = voltage waveform

$i_{ac}(t)$ = original current waveform before fault occurs

$i_{dc}(t)$ = DC component of the fault

$i(t)$ = fault current waveform

Figure 2.1: Fault Current Waveform Profile

At the moment of initiation of a fault, the fault current wave $i(t)$ is a combination of the original sine wave $i_{ac}(t)$ and the DC component $i_{dc}(t)$. The peak magnitude of $i(t)$ can be multiples higher than the original current, depending on system conditions such as power factor. The magnitude decays as a result of the DC exponential, which is a resultant of the system reactance and resistance known as the X/R ratio.

2.4 Circuit Breakers

Low voltage circuit protective devices include Molded Case Circuit Breakers, Low-Voltage Power Circuit Breakers, and insulated Case Circuit Breakers [42]. A circuit breaker is an electrical device designed to open an energized circuit under loaded conditions. All circuit breakers have the primary function of protecting the circuit conductors by detecting and interrupting over-currents [43]. The opening of an electrical circuit is in response to transient current conditions, such as an overload or fault in the system. Circuit breakers are rated by available interrupting capacity and rated continuous current. The interrupting capacity of a circuit breaker is the maximum current a circuit breaker is rated to safely interrupt at a specific voltage. This short-circuit current rating is normally expressed in rms symmetrical amperes and is specified by current magnitude only [39]. The continuous current rating is the amount of current a circuit breaker can carry until it reaches overload conditions and opens the circuit.

Until the late 1960s the only circuit breaker trip units available were thermal-magnetic molded case circuit breaker designs (MCCB) [39]. These circuit breakers were designed to be bolted on or snapped-into standard breaker panels. These devices are constructed in a solid case that is not capable of being disassembled for maintenance and repair.

The magnetic trip element is often referred to as the instantaneous trip time and reacts quickly in response to high level short circuit currents. The thermal element is typically some type of bi-metal that expands due to the heat in a circuit caused by current at overload that is less than the magnetic pickup threshold. The element then trips the MCCB after a time delay.

Circuit breaker trip curves are analyzed graphically in order to understand the time versus current application of the device. When displayed in this manner the plot is referred to as a time current curve (TCC). A typical time TCC for a 480 volt, 100 amp, non-adjustable thermal magnetic MCCB is displayed in Figure 2.2. Here it is shown that the thermal element is 100 amps at 1000 seconds and the instantaneous sensor is at less than 0.02 seconds for short circuit currents greater than 2500 amps. For a fault current level in the range of 900-1900 amps, the interrupting time is shown to be greater than one second.

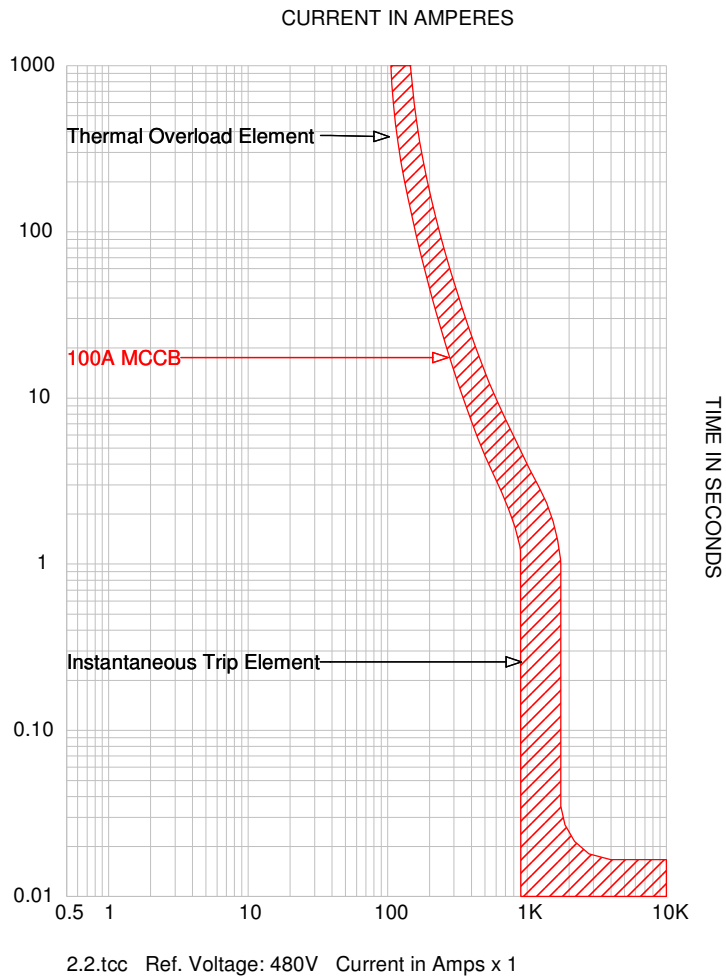

Figure 2.2: TCC Curve for 480 volt, 100 amp MCCB

Thermal magnetic MCCB's are also available with an adjustable magnetic trip setting. This is very useful in situations where the available fault current is low and quick interruption is important. Figure 2.3 shows a TCC for this type of circuit breaker. This plot introduces the flexibility available for the instantaneous trip setting when using an adjustable breaker.

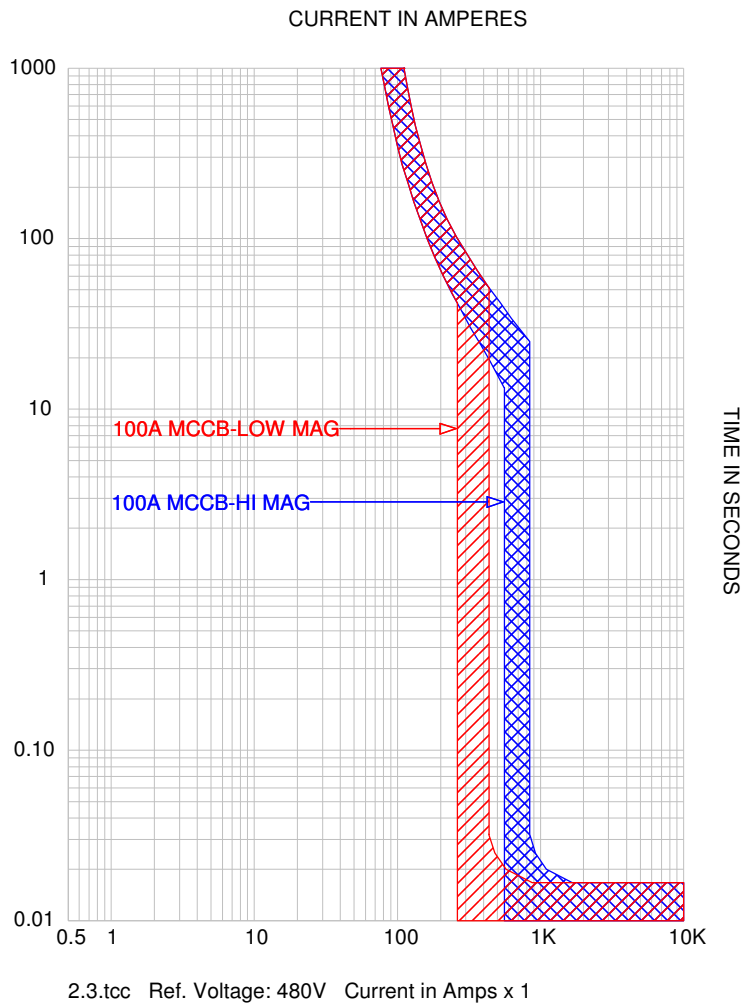

Figure 2.3: TCC Curve for 480volt, 100 amp MCCB with Low and High Settings

The next available circuit breakers manufactured in the late 1960's were the low-voltage power circuit breakers (LVPSBs). These circuit breakers were designed to be rack mounted in switchgear, have larger frame sizes and higher current ratings than MCCBs. These devices are maintainable and can be disassembled for cleaning of contacts and replacing parts.

The LVPCBs have thermal-magnetic trip units that respond to overloads in a similar manner as MCCBs: however, LVPCBs had a 30-cycle short time current rating consistent with ANSI standards [41]. This short time current rating allows for a second

breaker adjustment between the magnetic pickup and the long time sensor. These settings are commonly referred to as Long-Time (L), Short-Time (S) and Instantaneous (I), hence calling the breaker an LSI protective device. A TCC for a LVPCB is shown in Figure 2.4.

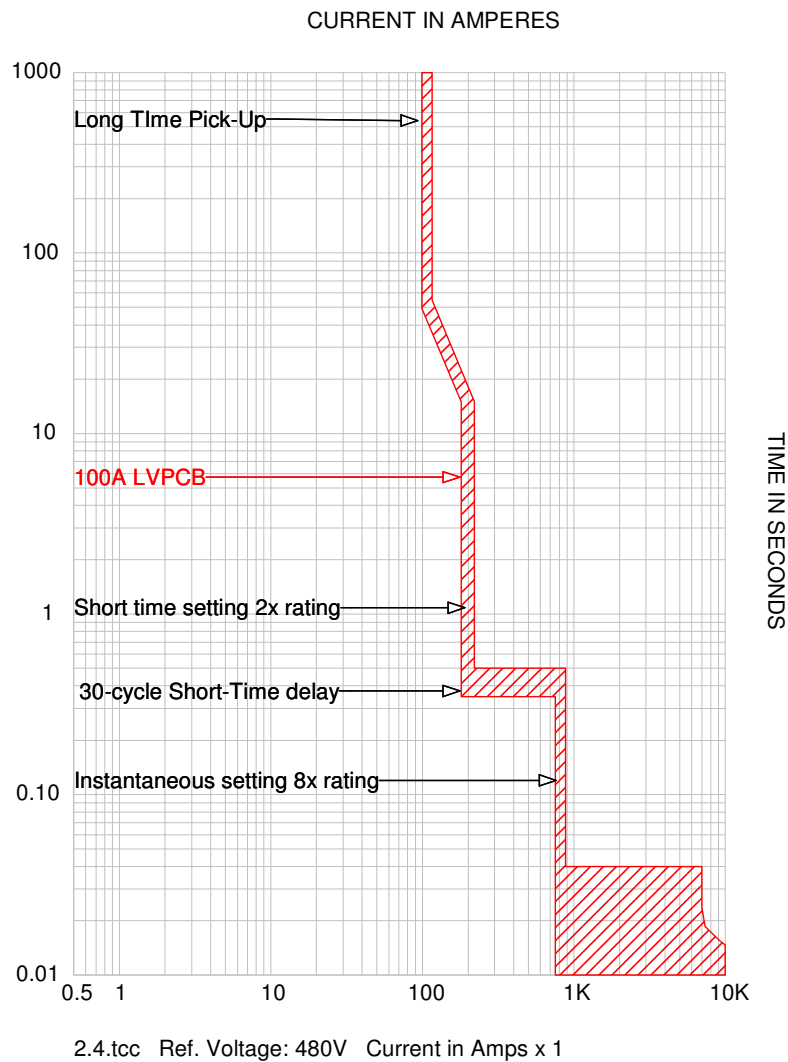

Figure 2.4: TCC Curve Showing 480 volt, 100 ampere LVPCB

The LVBCB has five adjustments in three time domains that allow for a circuit breaker curve to be custom fitted for the application.

1. Long Time Pickup is set at the overload amperage.

2. Long Time Delay allows the pickup to be postponed.
3. Short Time Pickup is the trip amperage after a delay time.
4. Short Time Delay postpones the short time pickup to a designated time.
5. Instantaneous pickup is the magnetic setting for immediate response.

The TCC for two 100 ampere LVPCBs showing lowest and highest settings at all pickups and time delays are displayed in Figure 2.5.

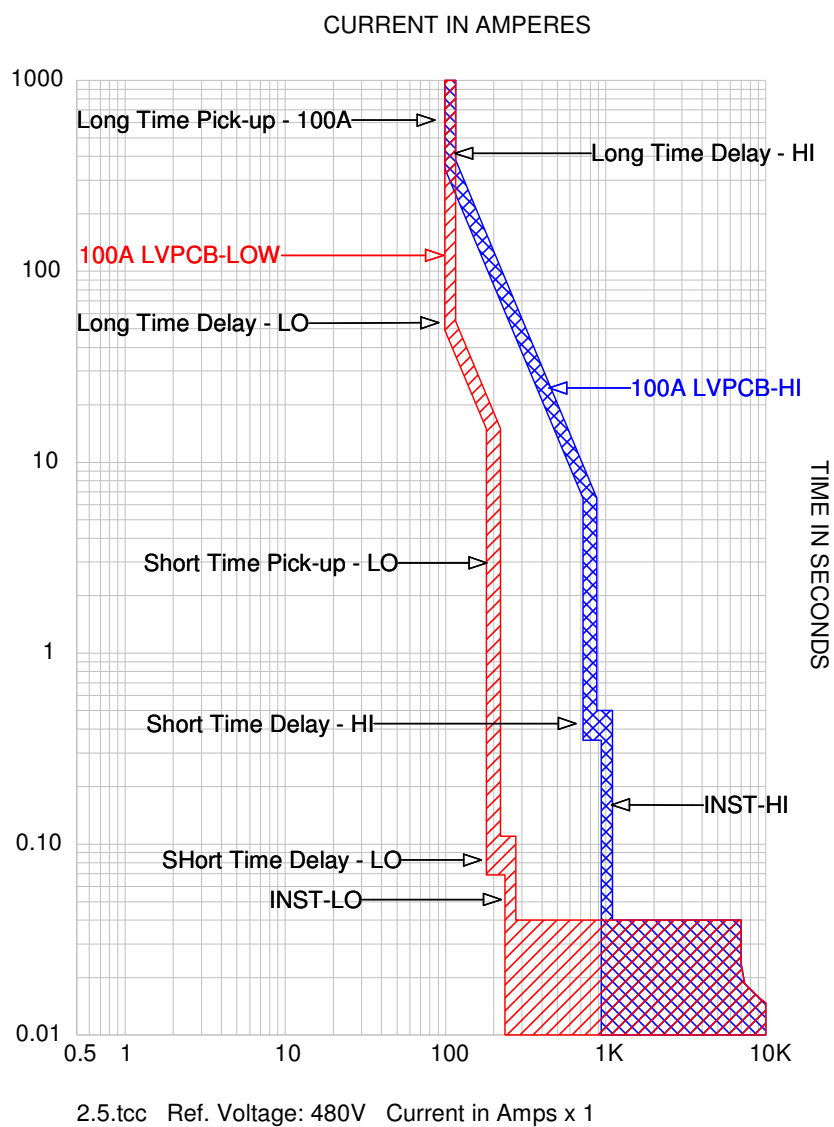

Figure 2.5: TCC Curve for 480 volt, 100 ampere LVPCB with LSI Settings

The Insulated Case Circuit Breaker (ICCB) was introduced in the mid-1970s. These devices were specially designed molded case circuit breakers that included some of the low-voltage power circuit breaker features [39]. These features included short time current duty cycles and a stored energy mechanism [43]. The ICCB had an instantaneous trip element that was capable of being set at a much higher trip level than the MCCB, which allowed some short time current ratings to be achieved.

2.5 Circuit Breaker Testing

In North America, low-voltage circuit breakers are designed and tested in accordance with ANSI/UL standard 1066, which refers to a series of applicable ANSI C37 standards [41,44,45,46]. Insulated case and molded case circuit breakers are designed and tested in accordance with UL standard 489 [40]. The UL standards 1066 and 489 consist of a series of tests and construction for required ratings, trip units, overloads, endurance, short-time current, temperature rise, and dielectric withstand. Each standard is specific in the guidelines for an acceptable device. One of the particular testing parameters is the X/R ratio or dc offset decay. All low voltage protective devices are tested at pre-determined X/R ratios per the table below [17].

Table 2.1 Test X/R Ratios for Protective Devices

DEVICE	Test X/R ratio
Low Voltage Power Circuit Breakers	6.6
Molded Case Circuit Breakers rated less than 10k AIC	1.7
Molded Case Circuit Breakers rated between than 10k & 20k AIC	3.2
Fuses, Insulated Case Circuit Breakers, Molded Case Circuit Breakers rated greater then 20k AIC	4.9

Outside of the general construction and withstand requirements, the main application for this project is the adjustable setting of a circuit breaker that primarily differs in the short-time. The low-voltage power circuit breakers are manufactured to meet the testing requirements of UL 1066 [43]. This testing requirement is different than the UL 489 standard, mainly because the low-voltage power circuit breaker is required to carry fault current for two 0.5 second periods and the molded case device does not have a short time requirement.

2.6 Fuses

The term fuse is defined by ANSI/IEEE Std 100-2001 as “an overcurrent protective device with a circuit-opening fusible part that is heated and severed by the passage of overcurrent through it” [50]. Fuses were first introduced in the 1880s and were used for the protection of lighting installations. They were located adjacent to lamps and were to protect them from excess currents caused by source-voltage fluctuations [47]. Over the years, this device has improved its uses to include many different applications throughout the electrical system. The fuse has a wide range of protection applications from micro-electronic components up to high-voltage power system protection.

The fuses used in 480 volt electrical systems are intended to protect the system from over-loads and fault currents. The basic operation of a fuse is a simple thermal process; the passage of excess currents through specifically designed fuse elements causes them to melt, and so isolate the faulty circuit [47]. The interrupting capability is altered by the fuse element and the filler in the fuse cartridge.

The fuse has no moving parts and, therefore, can be extremely fast acting upon the presence of high fault currents. The actuation of a fuse represents the end of its useful life and therefore the reliability and accuracy is maintained when new fuses are inserted into the circuit. The lack of moving parts leaves no ability to adjust the time domains of the fuse, which can be costly when trying to protect a system against fault currents. The TCC for a fuse is shown in Figure 2.6. The fuse curve shows the interrupting times for various levels of overcurrent. These interruptions can occur over a short range of time as shown by the minimum melt characteristic, which is the time the fuse begins to melt, and the total clearing characteristic, which is the complete interruption of the current.

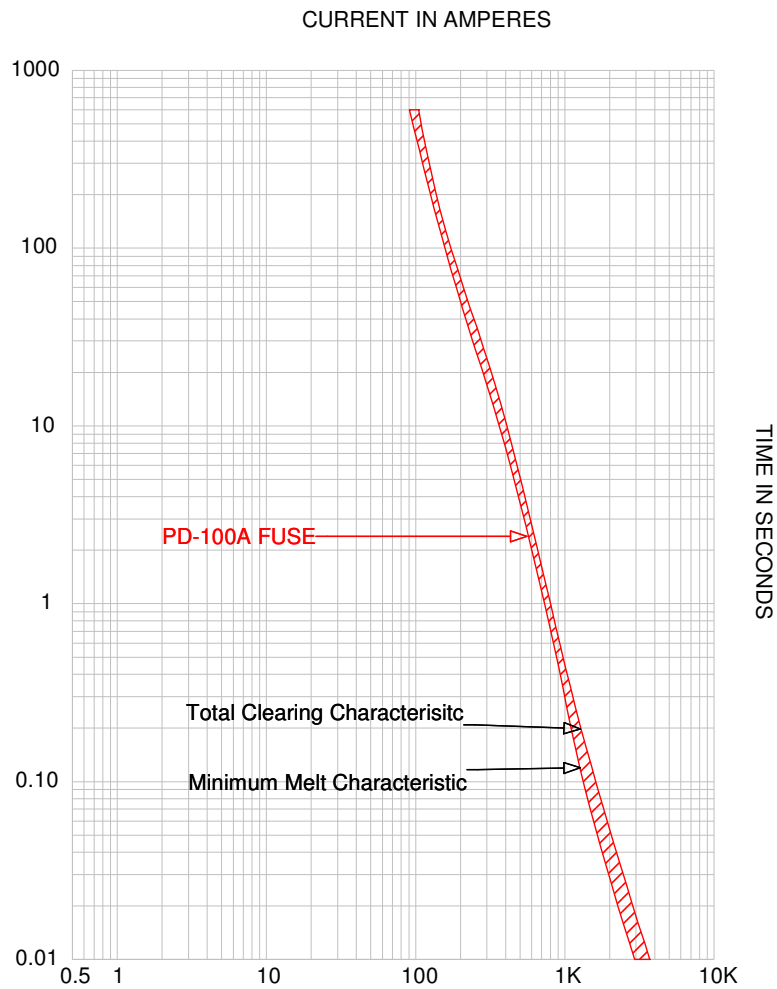

2.6.tcc Ref. Voltage: 480V Current in Amps x 1

Figure 2.6: TCC for 480 volt, 100 ampere Fuse

The TCC for the 100 ampere fuse has similar inverse time characteristics as the circuit breakers. This particular device is shown to have 100 amperes of over-load protection beyond 100 seconds. For a short circuit of 2000 amperes, this device interrupts at approximately 0.05 seconds.

3. ELECTRICAL POWER SYSTEM STUDIES

The electrical system must be studied with the anticipation of transients such as overloads and faults. This is accomplished by implementing a fault current analysis, protective device time current coordination study, and an arc flash hazard analysis.

This chapter is an overview of electrical power system studies for 480 volt power systems. The process of a fault current calculation will be conceptually described to show the purpose of the study and the software application. The utility source and its contribution to the system will be presented. The protective device coordination will be shown and the circuit breaker selections will be discussed. The arc flash hazard analysis will be presented and the resulting personal protective equipment requirements will be discussed.

3.1 Fault Current Analysis

The Fault Current Analysis or Short Circuit Study is an analysis of the electrical system under fault conditions. These faults can have many causes from adverse weather to aged insulation on conductors, to varmints chewing on the equipment. The result is a sudden electrical path from any phase to ground or any phase to another phase. In most cases these short circuits migrate to a three-phase fault and are studied from that perspective.

Analyzing fault current on a theoretical basis is accomplished by studying the response of the series R-L circuit shown in Figure 3.1 below.

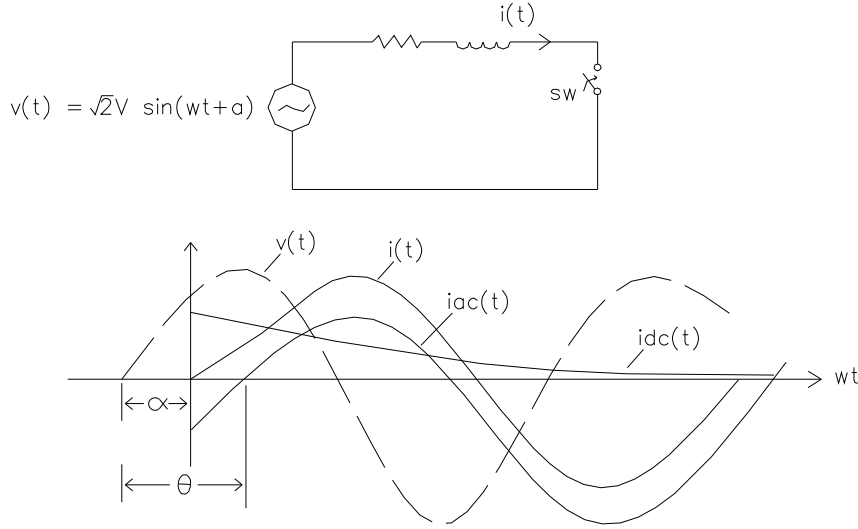

Figure 3.1: Series RL Circuit

When the switch SW closes at time $t=0$, the circuit will react in the same manner as a balanced three-phase fault with zero impedance between the phases [12]. Writing Kirchoff's Voltage Law for the circuit when $t > 0$:

$$\frac{Ldi(t)}{dt} + R(i)t = \sqrt{2V} \sin(wt + \alpha) \quad (3.1)$$

Solving this results in the fault current $i(t)$:

$$i(t) = \frac{\sqrt{2V}}{Z} [\sin(wt + \alpha - \theta) - \sin(\alpha - \theta)e^{-t/T}] \quad (3.2)$$

$$i(t) = i_{ac}(t) - i_{dc}(t) \quad (3.3)$$

$$Z = \sqrt{R^2 + (wL)^2} \quad (3.4)$$

$$\theta = \tan^{-1} \frac{wL}{R} = \tan^{-1} \frac{X}{R} \quad (3.5)$$

$$T = \frac{L}{R} = \frac{X}{wR} = \frac{X}{2\pi fR} \text{ sec} \quad (3.6)$$

To find $i(t)$ at its greatest value we allow $\alpha = (\theta - \pi/2)$, then:

$$i(t) = \sqrt{2}I_{ac}[\sin\left(\omega t - \frac{\pi}{2}\right) + e^{-\frac{t}{T}}] \quad (3.7)$$

The main purpose of the Short Circuit Study is to determine the available fault current (AFC) at locations throughout the system under fault conditions. The AFC is then compared to equipment withstand ratings and available interrupting capacity (AIC) of protective devices. Devices with a withstand rating do not interrupt fault current but must “ride through” a fault without damage imposed by the magnetic forces resulting from the large currents. Therefore, each panel-board must have a withstand rating greater than the AFC calculated at its bus. Each protective device must have an AIC greater than the AFC in order to be capable of interrupting the maximum fault current seen at its contacts. If a breaker or fuse is not rated to handle the maximum available fault current it might see, the device may not operate properly and its internal parts could fuse together or buckle under the destructive stresses of a fault condition, which can cause serious injury and/or property damage [11].

The AFC found at any point in an electrical system is a result of the fault contributions forced into the system and the impedances in their path to the fault location. The contributions toward the system consist of the utility, generators, and rotating machinery. The impedances throughout the system are supplied by conductors and transformers. An example of a basic electrical system with a faulted bus can be displayed as one utility serving one main circuit breaker switchboard shown in the partial one-line diagram in Figure 3.2.

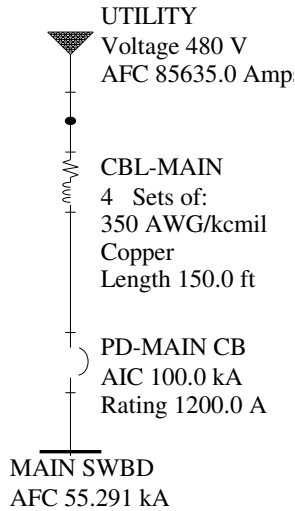

Figure 3.2: One-Line Diagram of Utility Serving Main SWBD

In this system, the utility is the lone fault contribution with only the impedance of the conductors in the path to the faulted bus. The AFC at the Main SWBD is calculated using computer simulation software for speed and accuracy. This project will be conducted with multiple scenarios of electrical systems requiring calculations which will be aided by computer software. The actual process of calculating a fault current has been very well documented in the IEEE Standard 141 Red Book and IEEE Standard 242 Buff Book and will not be duplicated here [49,15]. However, this attenuation of fault current can be estimated using a point to point calculation method by the following equation [15].

$$F = (1.732 \times L \times AFC) / (C \times n \times V) \quad (3.8)$$

where

- L Length of conductor
- AFC Available fault current a beginning of run
- C Constant representing conductor type
- n number of conductor parallel runs

V Voltage line to line

The AFC at the service entrance is a vital part of the calculation and is readily provided by the local electrical utility. Historically, this value is a very conservative large figure with the intent of evaluating the system during a worst case high fault current scenario. Therefore, the AFC is typically given as an infinite bus calculation that depends on the service transformer size and impedance. This results in the highest possible fault current that can be seen on the service transformer secondary terminals. The simple form of this calculation, based on infinite bus theory is indicated below [11]:

1. Step One: Calculate the full load current at the secondary of the transformer.

$$FLA \text{ (secondary)} = \frac{KVA(3-phase)}{KV(L-L) \sqrt{3}} \quad (3.9)$$

2. Step Two: Calculate the Available Fault Current at the secondary of the transformer.

$$AFC \text{ (secondary)} = \frac{FLA \text{ (secondary)} \times 100}{\%Z} \quad (3.10)$$

For a 13.2kV-480V, 1500kVA transformer with impedance (Z) = 5%, the resulting infinite bus calculation for AFC = 36,085 amps.

The idea of the infinite bus value being a conservatively high AFC can be tested as follows. Given the primary side distribution voltage of the 1500kVA transformer at a typical 13.2kV we will simulate the secondary AFC with a range of primary side AFC values. It is shown in Figure 3.3 and Table 3.1 that even for very high primary side AFC, the secondary AFC does not exceed the infinite bus value. Therefore, using the infinite bus method to calculate AFC is acceptable for evaluating AIC and withstand ratings of equipment.

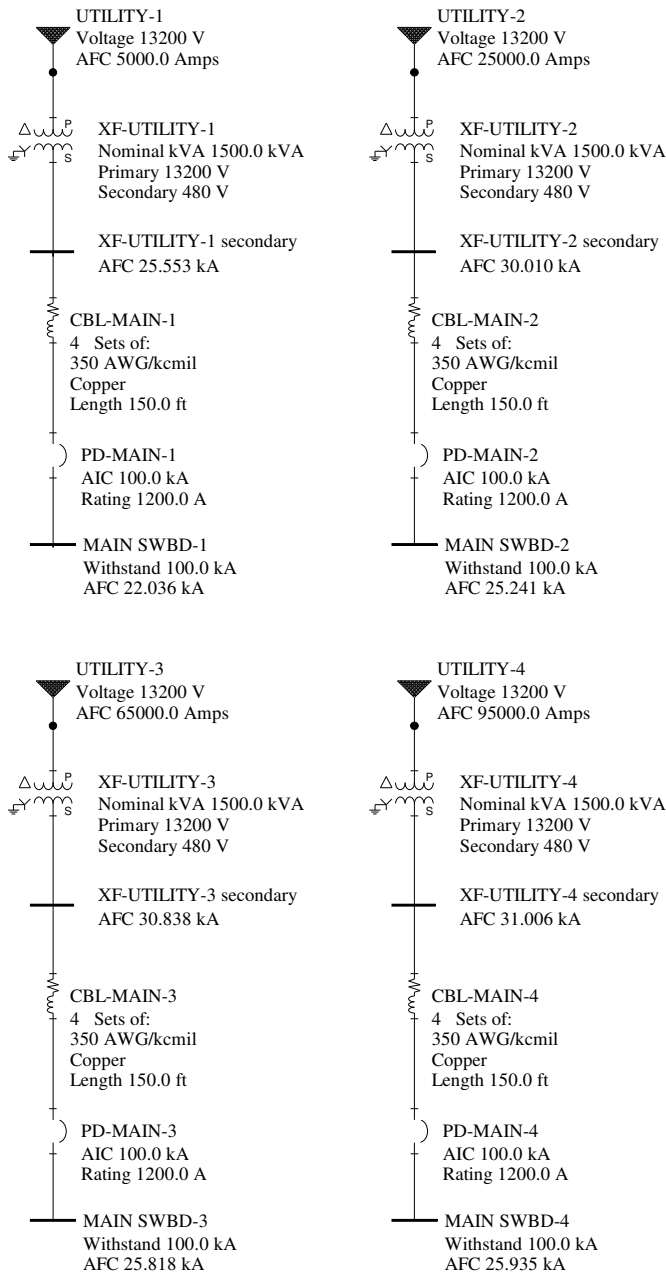

Figure 3.3: Utility Contribution One-Lines

Table 3.1 Simulation Results for 1500kVA Transformer with Z=5%

Primary Side Contribution	Transformer Secondary AFC
5,000 amps	25,553 amps
25,000 amps	30,010 amps
65,000 amps	30,838 amps
95,000 amps	31,006 amps

The peak value of the first cycle is a result of the DC exponential decay value. The rate of DC exponential decay occurs as a result of the system impedance properties when looking from the fault back to the short circuit contribution. The DC component of the current normally decays rapidly and reaches an insignificant value within 0.1 second in most power systems [12]. The conductor and transformer properties of resistance (R) and reactance (X) in calculation with the utility source system properties account for this value. This value is known as the X/R ratio and varies throughout the system depending on inherent properties. The protective devices must be measured against this value as well as the AFC.

Right after a fault occurs the current is no longer a sine wave. The waveform can now be represented as the combination of a sine wave and a decaying exponential. Figure 3.4 displays this waveform in a graphical setting.

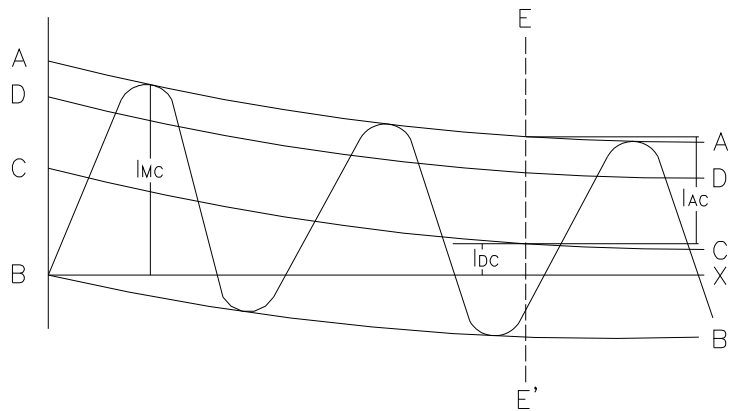

Figure 3.4: Fault Current Waveform

At the moment of initiation of a fault the ac current wave, which is normally symmetrical about the zero axis, BX is offset by some value, creating a waveform which is symmetrical about another axis, CC' [12]. The degree of the shifting is a result of the

circuit parameters and the location of the waveform when the short circuit was initiated. These system parameters also determine the rate of decay of the offset which is referred to as the DC current.

There are some important measurements shown in Figure 3.4. The value from BA, I_{mc} represents the asymmetrical peak value of the short circuit. This is termed asymmetrical because the waveform is no longer symmetrical about the time axis. This is the maximum instantaneous current in the major loop of the first cycle of short-circuit current. The rms symmetrical value of the short circuit current at any point in time, such as EE', is the rms value of the ac portion of the current wave. The value of the rms ac is equal to the ac current divided by the square root of two, and is shown graphically by the distance from CC' to DD'. The rms asymmetrical value of the short circuit current is the rms value of the combined ac and dc waves, and is calculated by the formula [12]:

$$I = \sqrt{\frac{(I_{AC})^2}{2} + (I_{DC})^2} \quad (3.11)$$

These different parameters and nomenclature of the sine wave are important when equipment is manufactured to meet various standards and specifications. The specification of the standards can require performance and testing based on certain parameters of the short circuit current.

The actual waveform of the asymmetrical fault current is hard to predict depending on exact moment during the voltage cycle the fault occurs. However, the largest asymmetrical fault current occurs when the fault happens at a point when the voltage is zero [51]. Then, the asymmetrical fault current depends only on the X/R Ratio and the magnitude of the symmetrical fault current. Figure 3.5 shows how the ratio of the peak asymmetrical current to RMS symmetrical current varies with the X/R Ratio [52].

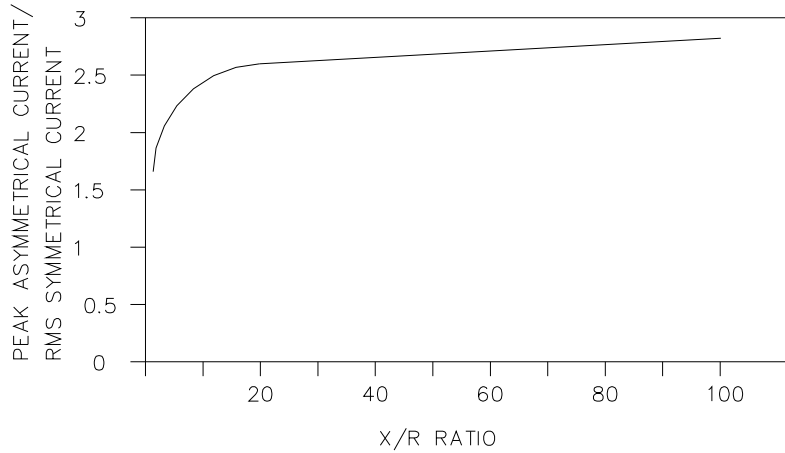

Figure 3.5: Peak Asymmetrical Current versus X/R Ratio

The devices manufactured for 480 volt systems have AIC and withstand ratings specified in RMS amperes. Furthermore, the AFC is calculated as an RMS value for consistency in equipment qualification and approval. Even though low voltage devices do not have asymmetrical ratings, if the test X/R Ratio and symmetrical current rating are known, the maximum asymmetrical fault current rating can be achieved from Figure 3.5.

The X/R value of the system is important because it determines the value of the fault current at 3-5 cycles after the fault which corresponds to the moment in time when the protective device will activate to isolate the fault. The higher the X/R ratio, the longer the DC component exists [16]. If the system X/R is greater than the protective device tested X/R, then further investigation is required to determine if the device is acceptable for use.

When the system X/R ratio exceeds the protective device tested X/R the AIC of the protective device shall be de-rated per the following multiplication factor [51].

$$MF = \frac{I_{ASYM} @ X/R_{CALCULATED}}{I_{ASYM} @ X/R_{TESTED}} \quad (3.12)$$

If the resulting de-rated AIC is greater than the AFC, then the device is properly rated for installation in the system at the specified location.

All low voltage protective devices are tested at pre-determined X/R ratios per the table below [51].

Table 3.2 Test X/R Ratios for Protective Devices

DEVICE	Test X/R Ratio
Low Voltage Power Circuit Breakers	6.6
Molded Case Circuit Breakers rated less than 10k AIC	1.7
Molded Case Circuit Breakers rated between than 10k & 20k AIC	3.2
Fuses, Insulated Case Circuit Breakers, Molded Case Circuit Breakers rated greater then 20k AIC	4.9

The short circuit study qualifies the equipment by measuring it against two parameters:

1. The AIC rating of the equipment against the calculated system AFC.
2. The X/R ratio at which the device was tested against the calculated X/R ratio of the system.

If both of these requirements are met, then the equipment is suitable for installation in the system at the location of calculation. Figure 3.6 shows a partial one-line diagram with simulation results for AFC and X/R Ratio. The Figure shows that the circuit breaker PD-MAIN CB has an AIC greater than the system AFC and a test X/R Ratio greater than the system X/R Ratio. The panel MAIN SWBD has a withstand rating greater than the system AFC and a test X/R Ratio greater than the system X/R ratio.

Therefore, both the circuit breaker and switchboard are sufficient for operating at this location within this electrical system.

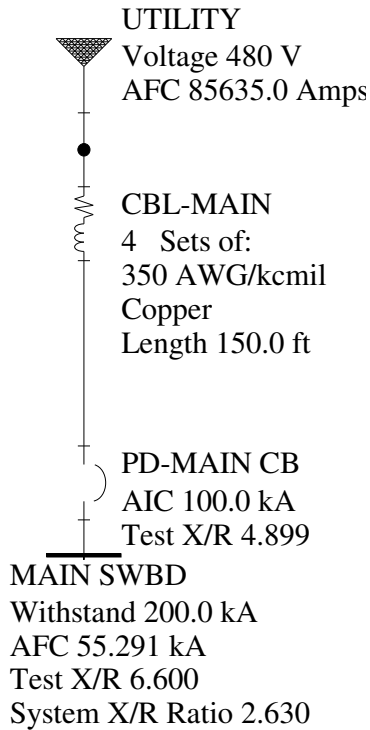

Figure 3.6: Partial One-Line Diagram Showing Fault Current Values and X/R Ratios

3.2 Protective Device Selective Coordination

Selective coordination first became a requirement in the 1996 National Electrical Code (NEC) in Article 620, “Elevators, Dumbwaiters, Escalators, Moving Walks, Wheelchair Lifts, and Stairway Chair Lifts” [34]. Section 620.62 required that protective devices in each disconnect be selectively coordinated with the supply side overcurrent protective devices, where more than one driving machine’s disconnecting means is supplied by a single feeder. The NEC further expanded the requirement for selective coordination in 2005 as part of Article 700, “Emergency System”, and Article 701 for

“Legally Required Standby Systems” in Sections 700.27 and 701.18 entitled “Coordination” [33]. The 2005 NEC defines selective coordination as “Localization of an overcurrent condition to restrict outages to the circuit or equipment affected, accomplished by the choice of overcurrent protective devices and their ratings or settings” [17]. These additions to the code expanded the selective coordination requirement to ‘Essential electrical systems of Health Care Facilities’. The 2008 NEC added the requirement for selective coordination into the new Article 708, “Critical Operations Power Systems (COPS)” [35]. Section 708.54, “Coordination”, requires that COPS overcurrent devices shall be selectively coordinated with all supply side overcurrent devices [35].

Protective device selective coordination is the response of circuit breakers and fuses during a transient, with the intent of isolating the faulted part of the system from service. The goal is to minimize the damage to equipment and personnel in nearby locations, while maintaining electrical service in parallel branches. This is particularly important in mission critical systems that this project is based on. It is stated in the IEEE Buff Book that, “Coordination is a basic ingredient of a well-designed electrical distribution system and is mandatory in certain healthcare and continuous process industrial systems” [15]. This coordination must be done for all protective devices in a series from the sources to the loads. When circuit breakers are properly set and installed, a fault at any location has minimal effect on nearby panels and feeders. A one line diagram of an electrical system is shown in Figure 3.7. If a fault occurred at Motor-1 then proper selective coordination would exist if circuit breaker PD-Motor-1 opened before PD-Panel-C or any device further upstream.

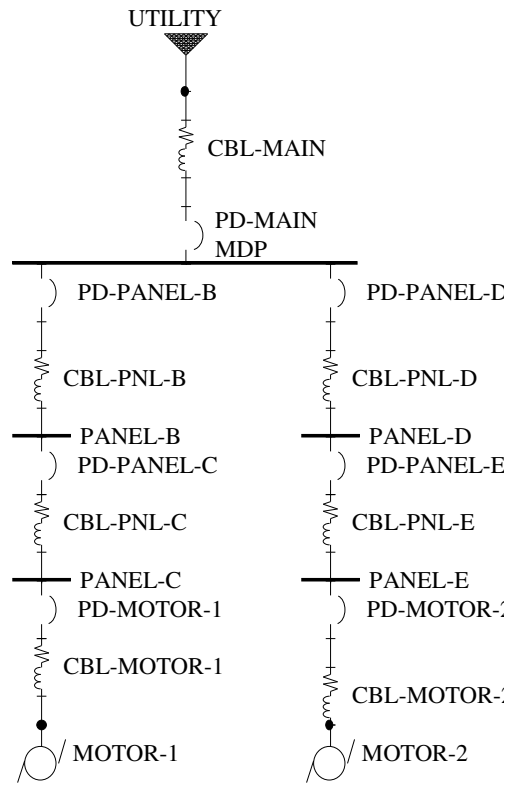

Figure 3.7: One-Line Diagram of a Two Motor Electrical System

The protective devices responsible for system selective coordination consist of fuses and circuit breakers. These devices have a profile of current versus time that they will allow to pass before activating that is referred to as a time-current curve (TCC). Figure 3.8 shows a TCC for circuit breaker PD-Breaker and fuse PD-Fuse.

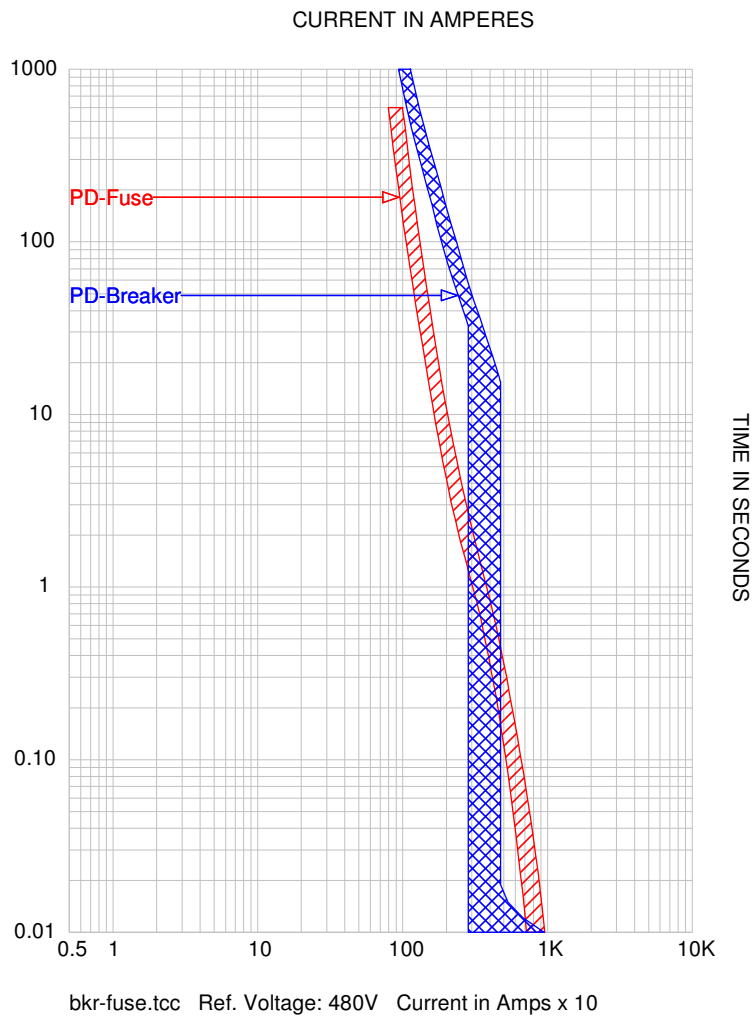

Figure 3.8: Time Current Curves for a Circuit Breaker and a Fuse

Since the reference voltage is 480 volt and the current is shown at times 10, a 6kA fault current would be cleared by this circuit breaker at 0.015 seconds and by this fuse at 0.9 seconds.

The TCCs for the system above with proper selective coordination is shown below in Figure 3.9. This plot shows all protective devices in the series from the Utility source to Motor-1.

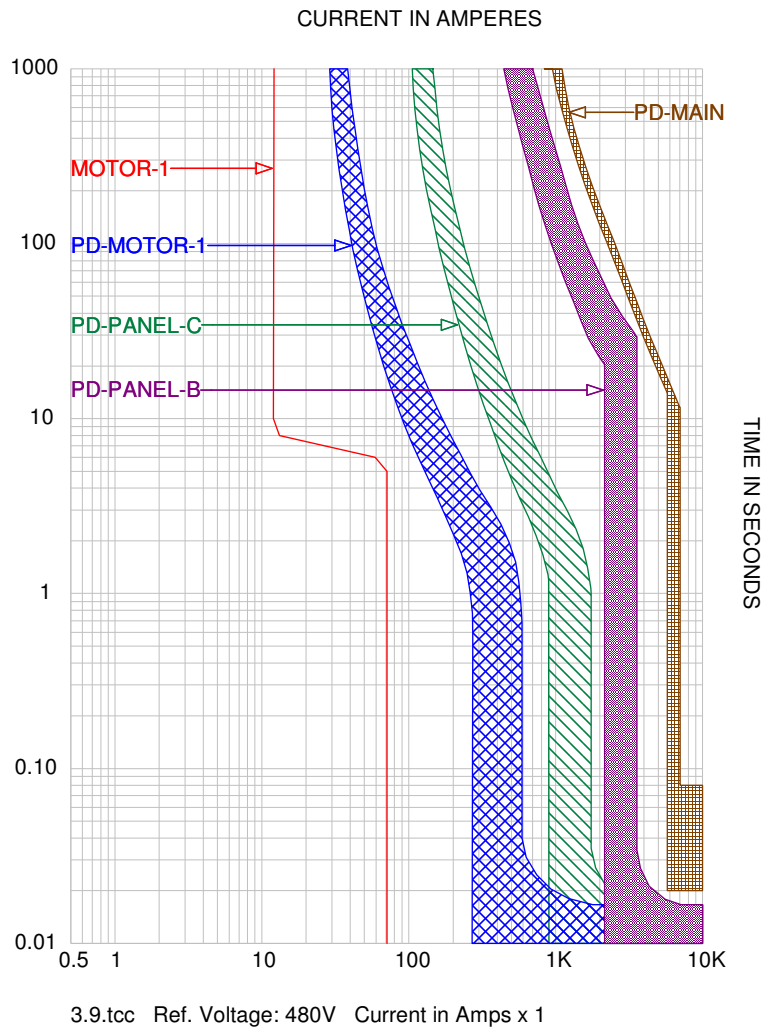

Figure 3.9: Time Current Curves for a Selectively Coordinated System

It is clear that the breaker curves do not touch or overlap each other and therefore proper selective coordination exists. The TCC for the system above is shown with a lack of selective coordination in Figure 3.10.

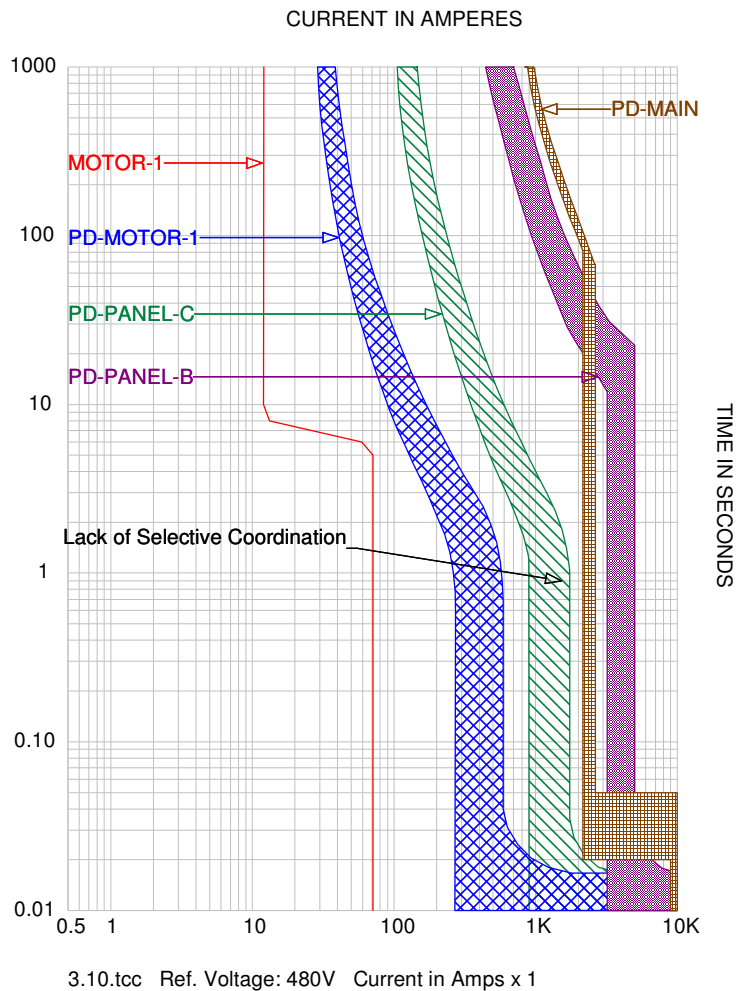

Figure 3.10: Time Current Curves with a Lack of Selective Coordination

The overlap of breaker curves PD-Main and PD- Panel B is evidence that selective coordination does not exist. If a fault of 2800 amps were to occur on Panel B, then PD-Main would open before PD-Panel B. This would cause the feeder to Motor-2 to lose power and our goal of isolating the fault without disturbing nearby devices would not be achieved.

Selective coordination is achieved by properly selecting and setting the protective devices. Actually, all electrical systems have a degree or some level of selective

coordination because the overcurrent protective devices closest to the source have higher ratings than the downstream devices [18]. This project focuses on coordination with circuit breakers because they can contain adjustable settings, where fuses do not. The adjustable features in a circuit breaker are divided by time segments. The Long Time (LT) is the setting of the breaker for overload conditions and is referred to as the amperage rating. This is generally in the time period beyond 60 seconds and reacts similarly to a thermal element. The Short Time (ST) is the setting for the breaker typically 0.5 seconds until the long time segment. This transitional period is important for sensing low level faults that may occur due to system impedances. The Instantaneous (I) element is the setting for the initial transient of a fault. This is often set very high to allow for motor and transformer inrush currents in the first few cycles of start-up but not higher than the available fault current.

Figure 3.11 shows two thermal magnetic breakers with identical Long Time amperage ratings and an adjustable setting in the Instantaneous region only. PD-Panel-B is set at the lowest setting Instantaneous setting and PD-Panel-D is adjusted to the highest setting. Therefore, they have different curve locations in the Instantaneous regions, but overlap in the Long Time domain.

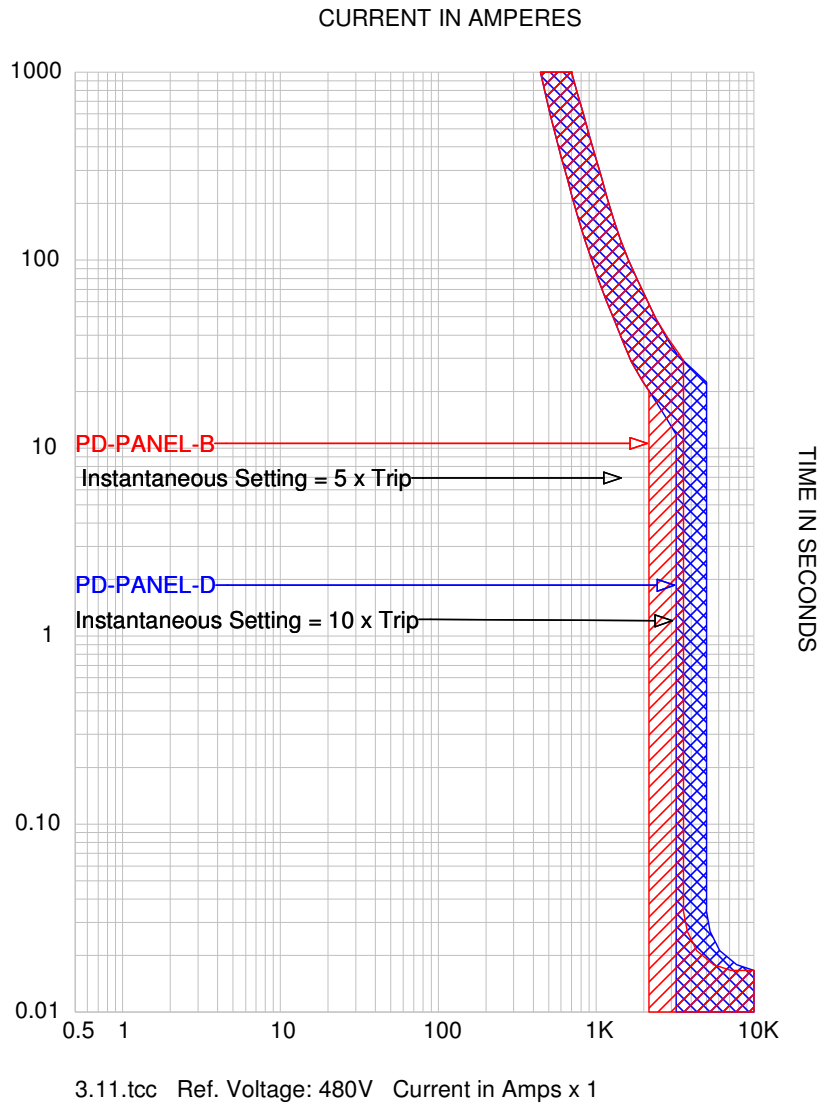

Figure 3.11: Time Current Curves for Thermal Magnetic Breakers

Figure 3.12 shows two electronic breakers with adjustable settings in the Long Time, Short Time, and Instantaneous regions. When a circuit breaker is specified with this type of setting options, it is referred to as an LSI device. PD-Main is set at the proper overload rating for Long Time and is shown at the lowest settings for Short Time and Instantaneous. PD-M2 is also set at the proper overload rating for the Long Time but is adjusted to the highest settings for Short Time and Instantaneous. Therefore, they have

different curve locations in the Short Time and Instantaneous regions but overlap in the Long Time. This shows that an LSI breaker can be set to protect for Long Time overload and still have a multitude of curve locations in the Short Time and Instantaneous regions. These curve locations can be adjusted for selective coordination with upstream and downstream protective devices. By specifying the proper breakers and adjusting the time domains, the goal of attaining selective coordination can usually be achieved.

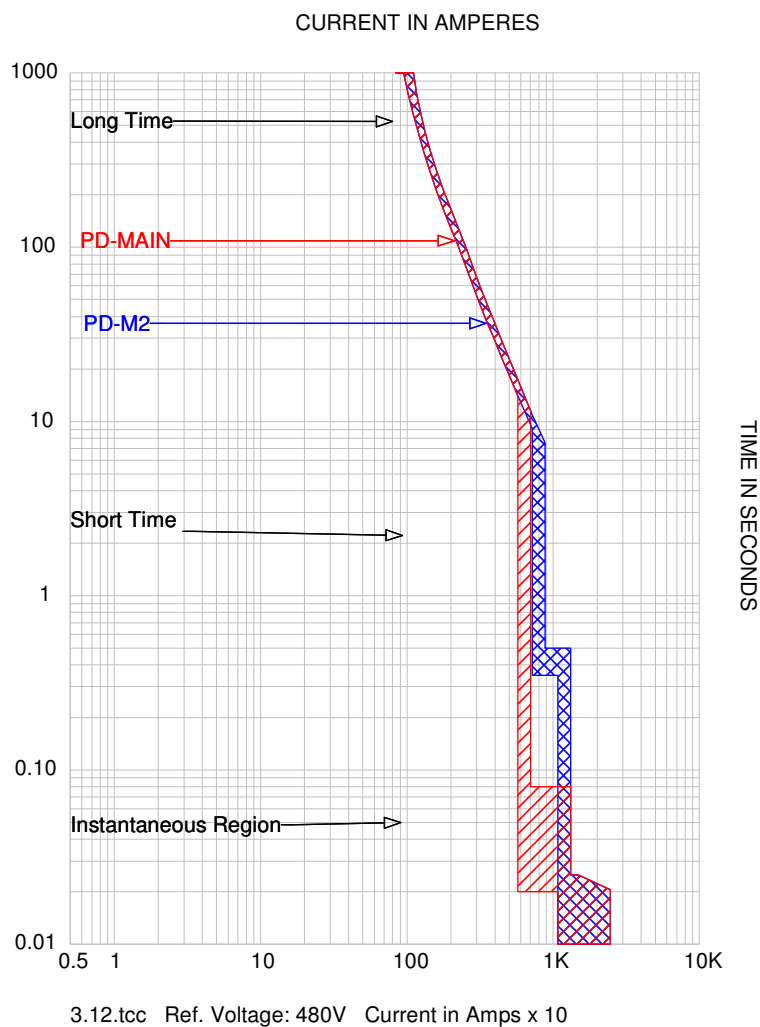

Figure 3.12: Time Current Curves for LSI Circuit Breakers

3.3 Arc Flash Hazard Analysis

Performing a fault current analysis and a protective device coordination study allows us to proceed with the arc-flash hazard analysis. An arc-flash hazard analysis should be performed in association with or as a continuation of the short-circuit study and protective-device coordination study [6]. The results from the short-circuit study are used to determine the available fault current at electrical equipment locations and therefore be able to properly specify equipment withstand ratings and interrupting capabilities. The results from the protective-device coordination study give us information on the time the system takes to isolate overload or fault conditions. The results of the short-circuit and protective device evaluation are used in combination to give us the necessary information required to perform an arc-flash hazard analysis. The results of the arc-flash hazard analysis are used to identify the flash-protection boundary and the incident energy at assigned working distances throughout any position or level in the electrical system [6].

IEEE-1584 defines an empirical method to calculate the incident energy from the arc due to heat, which is responsible for the most common effect of an arc-flash: burns [6]. This procedure does not consider other adverse effects of the arc flash such as pressure waves, molten metal, shrapnel or flying debris. This method is applicable over a specified range of voltages, fault currents, and frequencies. The multiple steps taken included calculating an arcing current, using that result to calculate incident energy, then applying that information to determine an arc flash boundary.

The first step in the arc-flash analysis is to calculate the arcing current. Arcing current is a short circuit via ionized gas between one live part and the ground or another live part [19]. Due to the arc resistance, the arc current is not the same as the available fault current. Arcing current is always lower than the bolted fault current [20, 21].

From the IEEE-1584 empirical derived model for a system under 1000V and having an available fault current between 700A – 106kA, the arcing current can be calculated as follows [6]:

$$\lg I_a = K + 0.662 \lg I_{bf} + 0.0966 V + 0.000526 G + 0.5588 V (\lg I_{bf}) - 0.00304 G (\lg I_{bf}) \quad (3.13)$$

where

- \lg is the \log_{10}
- I_a is arcing current (kA)
- K is -0.153 for open configurations and is -0.097 for box configurations
- I_{bf} is bolted fault current for three-phase faults (kA)
- V is system voltage (kV)
- G is the gap between conductors, (mm)

This project analyzed the effects of the arc-flash exposure for qualified technicians working on electrical equipment in a mission critical facility. Therefore, the K value is -0.097 to represent the arc occurring inside an electrical panel, switchboard, or motor control center. The system voltage V , for this project is 480 except when a step-down transformer is inserted to achieve a 208 volt feeder. The value for G is the gap spacing between the conductors or bus bars, which is dependent on equipment design.

This research studies low voltage switchgear which equates to a value of 32 from the IEEE-1584 table below.

Table 3.3 Classes of Equipment and Typical Bus Gaps

Classes of Equipment	Typical Bus Gaps (mm)
15kV switchgear	152
5kV switchgear	104
Low-voltage switchgear	32
Low-voltage MCCs and panelboards	25
Cable	13
Other	Not required

This reduces the arcing current equation (3.13) to:

$$I_a = 10^{(-0.034 + 0.833 \log / bf)} \quad (3.14)$$

The incident energy is a value that represents the amount of thermal energy that a person is exposed to at a given distance. Incident energy is measured in Joules per square centimeter (J/cm^2) and is defined as a watt second [6]. The calculations in this research are performed in the English system and, therefore, reports in the conversion nomenclature of calories per square centimeter (cal/cm^2). The incident energy, normalized for an arc duration of 0.2 seconds and a distance of 24" can be calculated given the arcing current above and using the following formula [6].

The Incident Energy normalized is calculated as follows:

$$\lg E_n = K_1 + K_2 + 1.081 \lg I_a + 0.0011 G \quad (3.15)$$

where

- E_n is normalized incident energy (J/cm^2)
- K_1 is -0.792 for open box configurations (no enclosure) and is -0.555 for box configurations (enclosed equipment)
- K_2 is 0 for ungrounded and high-resistance grounded systems and is -0.113 for grounded systems
- I_a is arcing current from above
- G is the gap between conductors (mm)

The constants K_1 and K_2 are dependent upon the physical enclosure of the circuit breaker. Since circuit breakers are mounted in a panel-board or switchgear it is in a box configuration. This will give a K_1 value of -0.555. The systems this project will analyze are grounded and therefore a K_2 value of -0.113 is appropriate.

This reduces the normalized incident energy equation (3.15) to:

$$E_n = 10^{(-0.633 + 1.081 \log I_a)} \quad (3.16)$$

For a different arc duration and/or distance from the arc, the normalized incident energy can be converted into the actual incident energy as follows [6]:

$$E = C_f E_n \left(\frac{t}{0.2} \right) \left(\frac{610^x}{D^x} \right) \quad (3.17)$$

where

- E is incident energy (cal/cm^2)
- C_f is 1.0 for voltages above 1kV and is 1.5 for voltages at or below 1kV
- E_n is normalized incident energy
- t is arcing duration in seconds
- D is the distance from possible arc point to the person (mm)
- x is the distance exponent

This equation can be reduced by verifying system parameters. This project analyzes systems at 480 volts and therefore C_f is 1.5. The value for the distance exponent x , is furnished by the IEEE 1584 table below.

Table 3.4 Distance x Factors

System Voltage	Equipment Type	Distance x Factor
208-1kV	Open Air	2.000
208-1kV	Switchgear	1.473
208-1kV	MCC and Panels	1.641
208-1kV	Cable	2.000

The value of D represents the distance from the exposed energized electrical conductor to the maintenance personnel working on the equipment. This value is standardized by IEEE 1584 depending on the class of the energized electrical equipment [6].

Table 3.5 Classes of Equipment and Typical Working Distances

Classes of Equipment	Typical working distance (inches) D
15kV switchgear	36
5 kV switchgear	36
Low-voltage switchgear	24
Low-voltage MCC's and panel-boards	18
Cable	18
Other	TBD

Using $x=1.473$ and $D = 18''$, reduces the incident energy equation (3.16) to:

$$E = 2.295 E_n(t/0.2) \quad (3.18)$$

Equations 3.14, 3.16, and 3.18 may now be combined into one equation which expresses the incident energy E as a function on I_{bf} and t , as follows [22]:

$$E = 2.295 \{ 10^{(-0.670 + 0.901 \log I_{bf})} \} (t/0.2) \quad (3.19)$$

Note that (3.19) is only valid for the assumptions made above, which are made for a power circuit breaker in an electrical system analyzed by this project (i.e., a solidly grounded 480 volt system, a circuit breaker mounted in a low-voltage switchgear, and at a working distance of 18").

The arc-flash hazard analysis provides important information that helps establish a safety barrier for workers when exposed to energized equipment. The incident energy level that will cause a just curable burn or a second degree burn is 1.2cal/cm^2 [4]. If a butane lighter is held 1 cm away from a person's finger for 1 second and the finger is in the blue flame, a square centimeter area of the finger will be exposed to about 1.2cal/cm^2 [6]. The entire premise of safety and arc flash is based on a curable or second degree burn

and, therefore, the incident energy level of 1.2cal/cm² is an important value. The distance away from an exposed energized conductor that is calculated at 1.2cal/cm² is known as the arc-flash boundary. This can be calculated by rearranging equation (3.17) and solving for distance at an incident energy of 1.2cal/cm².

$$D_b = \{4.184 C_f E_n (\frac{t}{0.2})(610^{x/E_b})\}^{1/x} \quad (3.20)$$

where

D_b is the boundary from the arcing point or the flash protection boundary

C_f is 1.5 for voltages at or below 1Kv

E_n is incident energy normalized

E_b is incident energy at boundary distance

t is time in seconds

x is the distance exponent from Table 3.3

After comparing equations 3.19 and 3.20, it is clear that the determining factors for the incident energy level are the arcing current that results from the available fault current and the time that the arc exposure exists. These factors are controlled by the system in which the circuit breaker is installed and the interrupting characteristics of the circuit breaker. Figure 3.13 shows a circuit breaker time current curve with the arcing current crossing it.

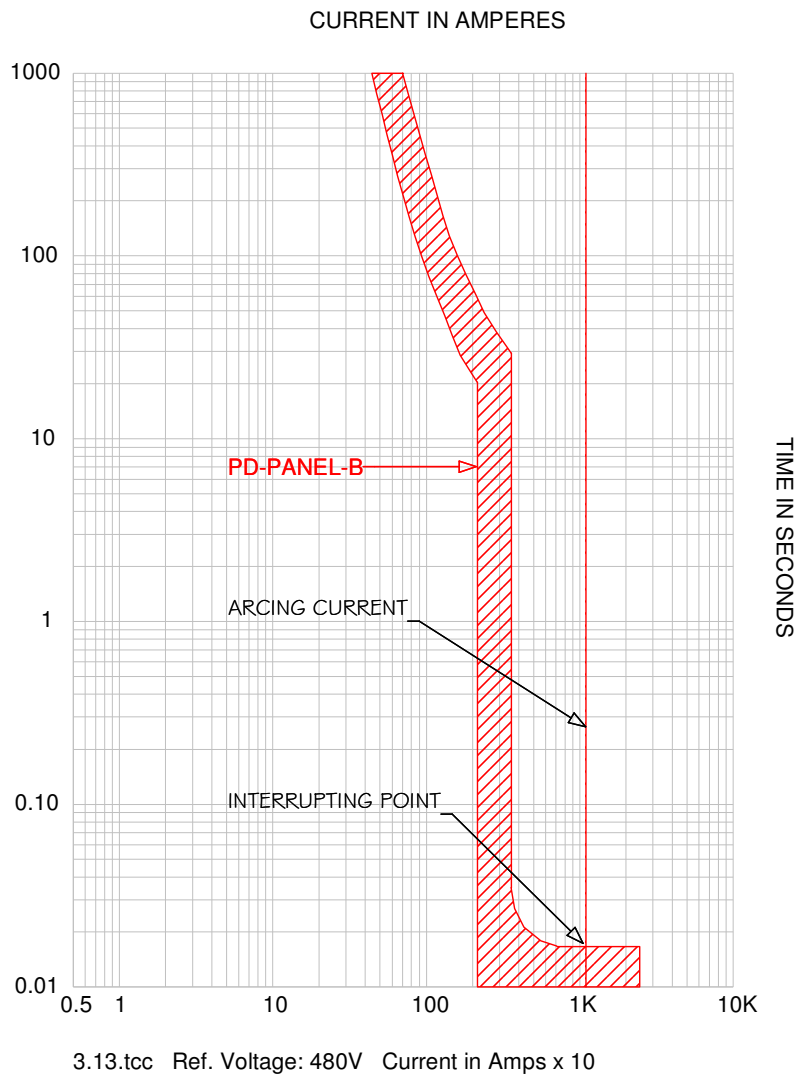

Figure 3.13: Circuit Breaker TCC Interrupting Arcing Current

Here it is shown that an arcing current of approximately 10.9kA is interrupted by the circuit breaker PD-PANEL-B at a time of 0.0175 seconds. This entire process is recalculated at a fault current level of 85% less than the reported AFC. This allows for a worse-case scenario if the fault current is lower than anticipated. This arcing current is simultaneously plotted against the protective device curve and the slowest interrupt time is used in calculating the incident energy. Figure 3.14 shows both arcing currents plotted against PD-Panel-B.

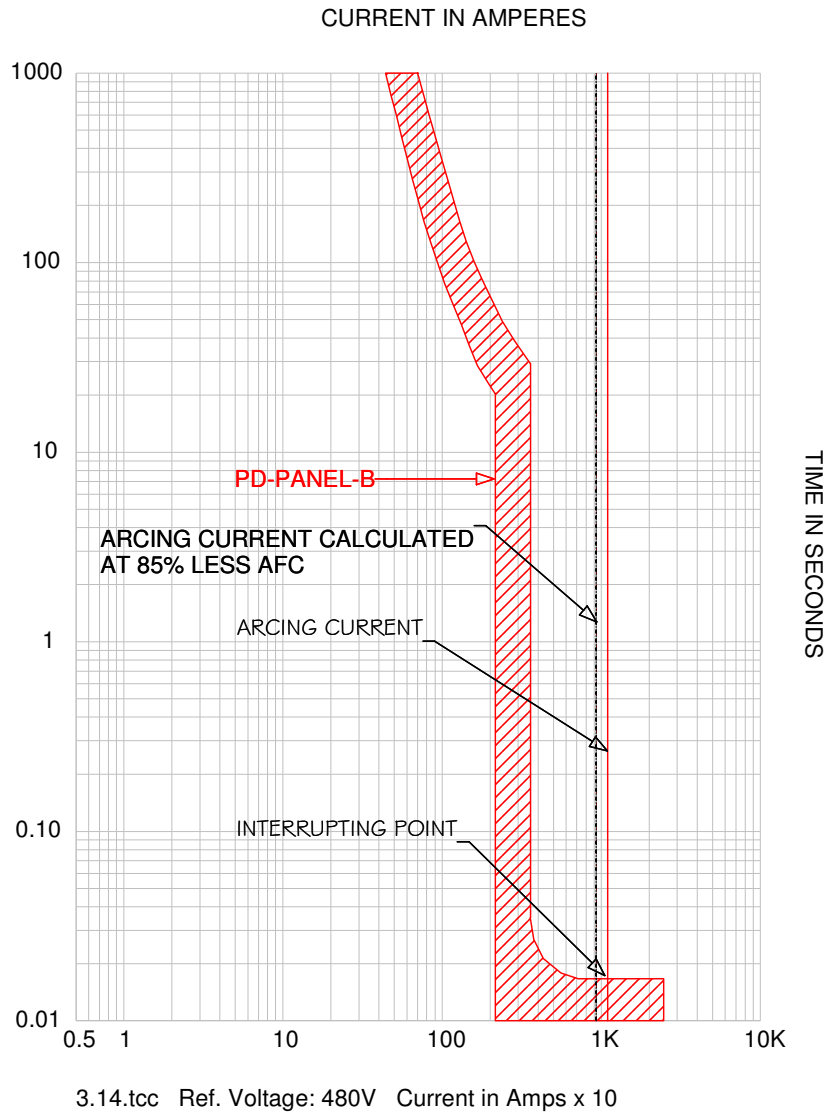

Figure 3.14: Circuit Breaker TCC Interrupting Arcing Currents

This information can be used in the equations above to calculate the incident energy for Panel-B. The computer simulation output results are shown in the partial one-line diagram in Figure 3.15.

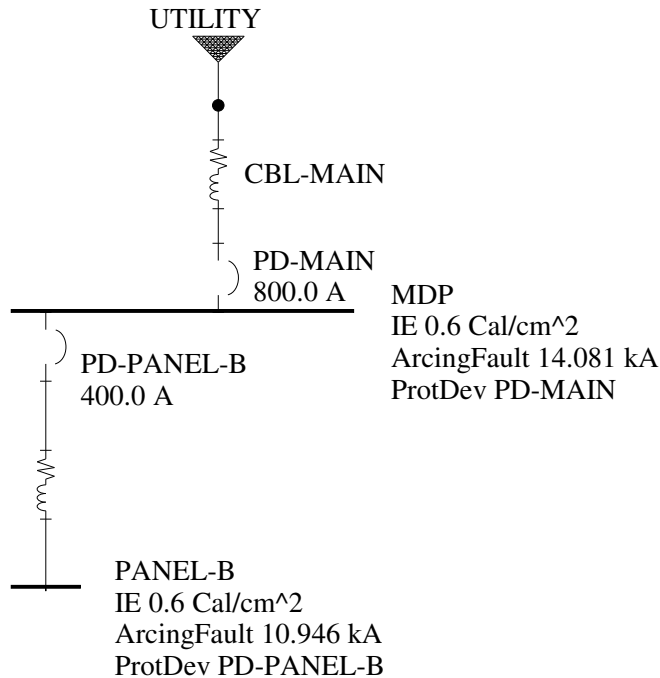

Figure 3.15: Partial One-Line Showing Panel-B Incident Energy

With this information of an incident energy level of 0.6 cal/cm², the qualified technician can select clothing and personal protective equipment rated for arc-flash safety. The clothing and equipment selected must always have an arc flash rating greater than the incident energy at the electrical device to be maintained. Since the incident energy level can have a multitude of values ranging from 0.1cal/cm² up to over 40cal/cm², the amount of different clothing devices could be enormous. Therefore, the concept of grouping the incident energy levels into categories arose.

3.4 Arc Flash Hazard Risk Categories

While incident energy prediction was being researched, there were also studies being conducted on how to protect workers in the event of an arc-flash. In 1997 and 1998, two papers on the testing of Personal Protective Equipment (PPE) for Arc-Flash Exposure were published [8,9]. This project tested the flammability of clothing when exposed to arc flashes of differing incident energy magnitudes. Ultimately the paper proposed protective clothing classes based on ranges of incident energy exposure which correlated to a fire rated clothing system and description. This project also included the performance of safety glasses, face shields, and work gloves when exposed to an arc-flash. This research provided the ground work for a standardized system focused on worker safety in the event of an incident.

In parallel with the developments of the IEEE Standard, the NFPA 70E Standard for Electrical Safety in the Workplace was created [10]. A portion of this document covers the need for informing employees of the electrical arc flash hazard they are exposed to when working on energized equipment. NFPA 70E divides incident energy levels into hazard/risk categories ranging from 0-4. Each category is given a clothing description and a required minimum arc rating of personal protective equipment. These categories are very similar to those suggested by Neal and Bingham. [8,9].

The Arc Flash Hazard Analysis gives us an incident energy level at a specified working distance from the source of the arc. This enables us to select Personal Protective Equipment (PPE) that is rated above the incident energy. Although the concept of wearing PPE that is suited for the task is simple, the different incident energy levels can

be numerous. Therefore, the implementation of hazard risk categories was instituted into the PPE selection process.

There are hazard risk category levels 0,1,2,3, and 4 which correlate to maximum incident energy levels (cal/cm²) of 1.2, 4, 8, 25, 40. This allows for an electrical device to be labeled per category and the selection of PPE can be matched the same way.

Table 3.6 Hazard Risk Categories and PPE Characteristics

Hazard Risk Category (HRC)	Typical Protective Clothing Systems	Required Minimum PPE Arc Rating (cal/cm²)
0	Non-melting, flammable materials(natural or treated materials with at least 4.5 oz/yd ²)	N/A (1.2)
1	FR pants and FR shirt, or FR coverall	4
2	Cotton Underwear, plus FR shirt and FR pants	8
3	Cotton Underwear, plus FR shirt and FR pants and FR coverall	25
4	Cotton Underwear, plus FR shirt and FR pants and multi-layer flash suit	40

The partial one-line diagram for Panel-B can now include a hazard risk category also known as a PPE Category as shown below in Figure 3.16.

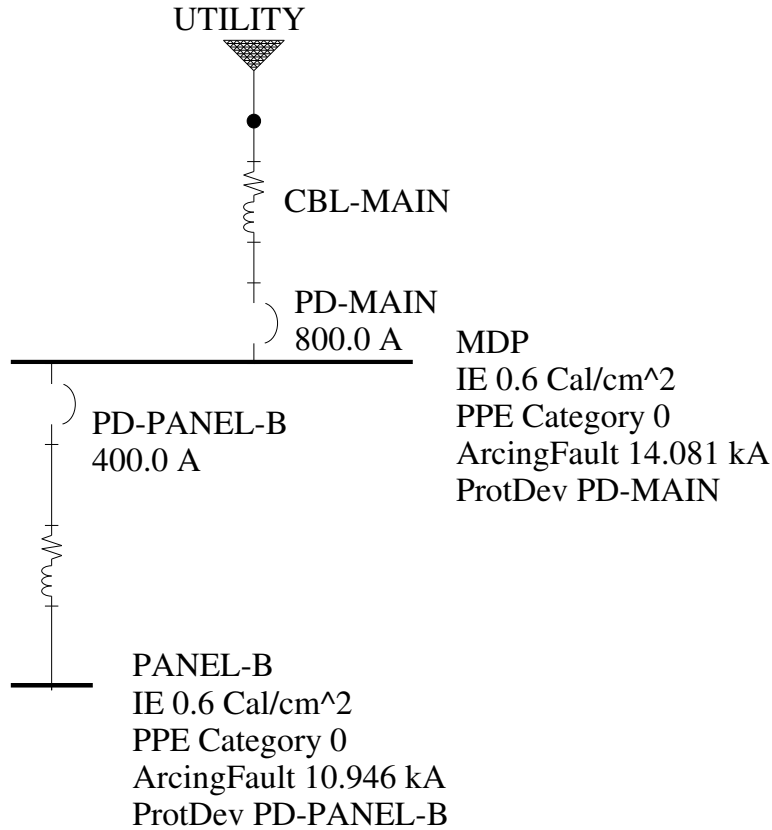

Figure 3.16: Partial One-Line Showing Panel-B Incident Energy and Hazard Risk Category

Per Table 3.6, the highest hazard risk category is level 4, with a maximum incident energy of 40cal/cm². While PPE is certainly available in ratings well above 40cal/cm², working near exposed energized electrical equipment above 40cal/cm² is discouraged [27]. Annex D of NFPA 70E notes that, “greater than normal emphasis should be placed on de-energizing the equipment” (Annex D.8 FPN) at such high incident energy levels.

4. EXISTING ARC FLASH HAZARD MITIGATION TECHNIQUES

This chapter will present existing products, techniques and devices aimed at mitigating the arc flash hazard exposure. These products and techniques will be computer simulated with before and after simulations of the electrical system. The implemented equipment and techniques will show a decreased arc flash hazard incident energy and category.

4.1 Changing Work Methods and Procedures

The approach of changing work methods for mitigating arc flash hazards focuses on the existing calculations and changes of the environment to decrease arc flash exposure. Incident energy reduction approaches by changing working methods include changing work procedures, modifying existing settings, and increasing work distances [24].

There are multiple work procedures that can be implemented to reduce arc flash exposure. The best work practice to avoid exposure is to work in the de-energized state [25]. NFPA 70E devotes an entire section to de-energizing or the process of achieving an electrically safe work condition. However, this is typically not possible in mission critical facilities where life support equipment is dependent on a constant power supply. Energized work shall be permitted where the employer can demonstrate that de-energizing introduces additional or increased hazards such as the interruption of life

support equipment, deactivation of emergency alarms, and shutdown of hazardous location ventilating equipment [10].

There are workmanship and technical training procedures that can be instituted to decrease the arc-flash exposure. A specific example is by changing locations when taking measurements with a power quality meter. Historically, measurements have been performed by direct connection of the voltage and current probes to the primary circuit, where incident energy can be relatively high [24]. By taking the measurements at the potential transformers and current transformers, the arc-flash exposure can be reduced.

4.2 Temporarily Modifying Existing Protective Device Settings

One of the most common and easiest arc flash mitigation techniques is to temporarily modify the existing settings of the first upstream protective device. This can be accomplished by lowering the instantaneous setting of the circuit breaker that is protecting the equipment to be worked on. An example of this is shown by the partial one-line diagrams in Figure 4.1.

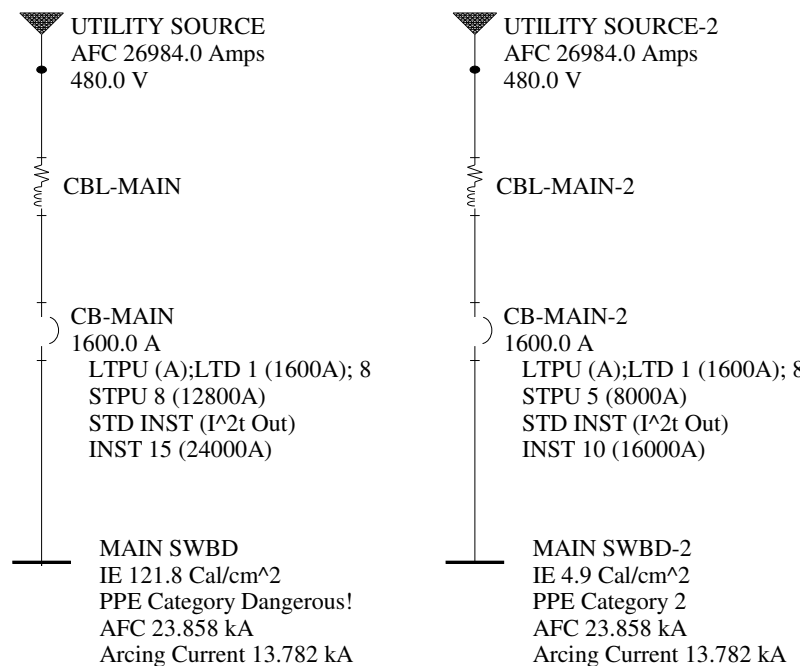

Figure 4.1: Incident Energy Before and After Temporary Setting of Breaker CB-Main

Here, it is shown that by lowering the instantaneous setting of circuit breaker CB-MAIN from 15 (24000A) to 10 (16000A) the incident energy decreases from 121.8cal/cm² to 4.9cal/cm² and the PPE Category decreases from Dangerous to HRC 2. Care must be taken when implementing this solution, as protective device coordination may be affected when reducing the clearing time of protective devices [24]. Furthermore, there must not be any devices downstream that could require sudden in-rush of current that could trip the lowered instantaneous setting. The starting of a motor or energizing a transformer could draw up to six times the operating amps for that device and therefore cause a circuit breaker trip in the instantaneous time domain.

4.3 Increasing the Working Distance

The calculations from IEEE-1584 for incident energy involve several unknowns that must be collected in order to achieve an accurate result. However, the most critical variables are the distance from the arc and the time to interrupt the fault. Since the incident energy is proportional to the square of the distance (in open air), increasing the working distance will significantly reduce the incident energy [23]. Care must be taken when implementing this solution because increasing the distance could hinder a person's ability to work on the equipment [24]. Working distance can easily be increased by using remote racking devices, remote operating equipment, and extension tools. Where the equipment design permits, it is very beneficial to carry out all switching operations remotely, away from the switch gear [25]. Racking and switching of a low voltage power circuit breaker is probably the highest exposure that will occur in industrial facilities [27]. One way to reduce the hazard is to lengthen the tool used to rack the breaker, or use remote racking/switching equipment that is available from manufacturers or other suppliers [27]. The partial one-line diagrams in Figure 4.2 show the effectiveness of increasing the working distance.

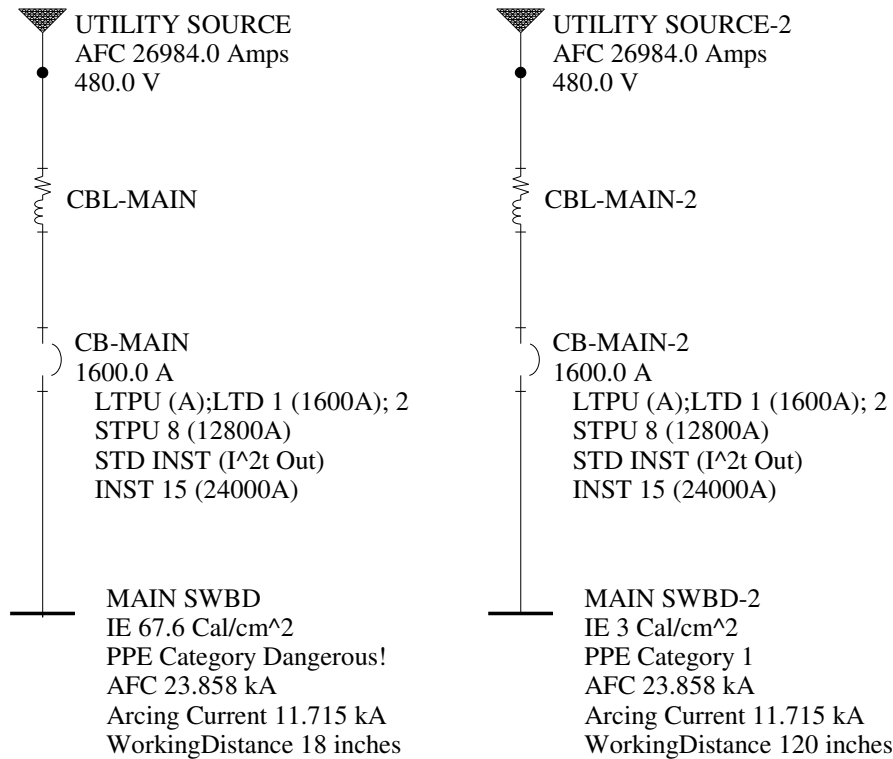

Figure 4.2: Incident Energy Before and After Increasing Working Distance

Here it is shown that by increasing the working distance from 18 inches to 10 feet through the use of a remote racking device, the incident energy decreases from 67.6cal/cm^2 to 3cal/cm^2 and the PPE Category decreases from Dangerous to HRC 1.

4.4 Arc Flash Resistant Switchgear

The selection and specification of electrical equipment can be accomplished with the inclusion of arc-flash hazard properties. However, the design and manufacturing specification should be carefully reviewed before purchasing equipment. Low voltage switchgear and control gear assemblies are tested for short time and short circuit withstand according to IEEE C.37.20 [29]. Many new designs are available from manufacturers to reduce the arc flash hazard exposure [25]. Arc flash resistant switchgear

is a new manufacturing procedure for the mitigation of incident energy exposure. Arc-resistant switchgear is tested to withstand an internal arc, and ensure that the person operating the switch or working on the equipment is not exposed to the hazard [28]. This is typically accomplished by ventilating the energy out of the top of the switchgear or some direction away from the worker. Although this is an excellent idea for personal protection when the equipment is closed, the worker is generally engaged with the devices when the enclosure is open.

4.5 Optical Light Sensor Technology

Electrical system protection is designed to interrupt the flow of electricity in the event of an overcurrent or fault condition. When an arc flash occurs the arcing time is a critical factor in limiting the damage and risk of personal injury resulting from an arc flash [26]. Therefore, the faster the relay senses the arc-fault, the lesser the incident energy will be and the safety of the worker is increased. Optical sensor technology detects the light from the arc-flash and initiates a shutdown.

When an arc flash occurs there is a tremendous release of radiant energy that consists of audible, thermal, light, and other energy properties. The light intensity of the arc flash is comprised of different wavelengths than visible light. Visible light consists of the light spectrum ranging from 400nm to 700nm wavelengths but arc flash tests have shown to produce wavelengths in the range of 200nm to 600nm. Consequently, optical arc flash relays are designed to operate in the lower end of the visible spectrum and slightly lower including ultraviolet light [30].

An optical arc flash detection relay system requires a light sensor and a current measuring device. The light sensor detects the sudden change in the light spectrum wavelength and the current measuring device detects the change in instantaneous over-current. Tripping only occurs if both light and fault current are detected [30]. These relays are equipped with solid state technology for additional speed and they utilize peak to peak measurements to avoid the delay associated with root-mean-square calculations. The total operating time is typically less than 2.5ms for the relay [31]. After the relay sends a signal to the disconnecting device, it is another 5 cycles or 84ms for circuit breaker opening time. This equates to a total arc flash detection and interrupting time of approximately 0.09 seconds.

This type of system is dedicated to arc-flash protection and can be viewed as a stand-alone system. When in use, this avoids the process of coordinating with upstream and downstream protective devices. However, if more dedicated arc flash protection was added to the system, then time delays for trip time should be selectively coordinated.

The optical sensing device most often used is a fiber optic cable that can be up to 200 feet long. The cable is constructed of plastic fiber with a glass core and is routed throughout all switchgear compartments where an arc flash could occur. The routing for the fiber optic cable in two-high construction switchgear is shown in Figure 4.3.

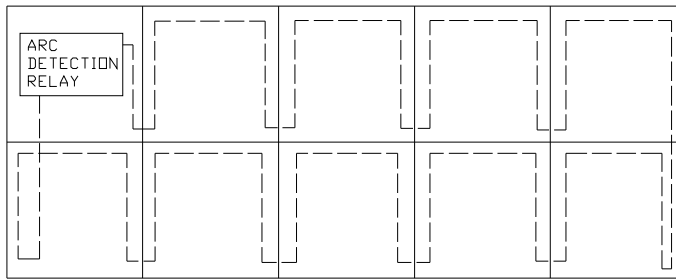

Figure 4.3: Typical Fiber Optic Routing in Switchgear

The fiber is shown routed in a continuous loop to allow for the option of continuous monitoring by the arc detection relay. This can be accomplished by sending a test pulse through the system at periodic intervals. If the test pulse is not received as programmed, then an alarm can be activated to alert maintenance personnel of an equipment failure.

Unlike communication fibers, this optical sensor has no cladding to prevent ambient light from entering the fiber [23]. This is vital to the operation because the system depends on external light to alert of an arc flash. The lack of opaque fiber cladding allows some of the light to enter through the exposed cylindrical exterior surface, where it propagates back to the electronics. When arc flash occurs, the system will detect the light and the relay will send a trip signal to the circuit breaker. The light sensor system can be operated in automatic or manual mode. In automatic mode, the system continually adjusts its pickup to normal slow changing background light levels and therefore any false trips associated with opening an equipment enclosure door can be avoided. Manual light intensity level settings may be more appropriate where some normal low-level arcing might take place such as in older air-magnetic switchgear [23]

To supervise the instantaneous overcurrent change during a fault, the relay has inputs for a signal from conventional 5 amp current transformers. These are typically connected to the current transformers located on the source side of the main breaker and are used to drive instantaneous phase and ground over-current elements [26]. These over-current elements behave as fault detectors and signal the relay when a rapid change in current is detected. Fault detector supervision is selectable but recommended by the manufacturer for most applications [23]. When both the optical and fault detection systems indicate an arc-flash, the relay will send a trip signal to the circuit breaker. A block diagram is shown in Figure 4.4.

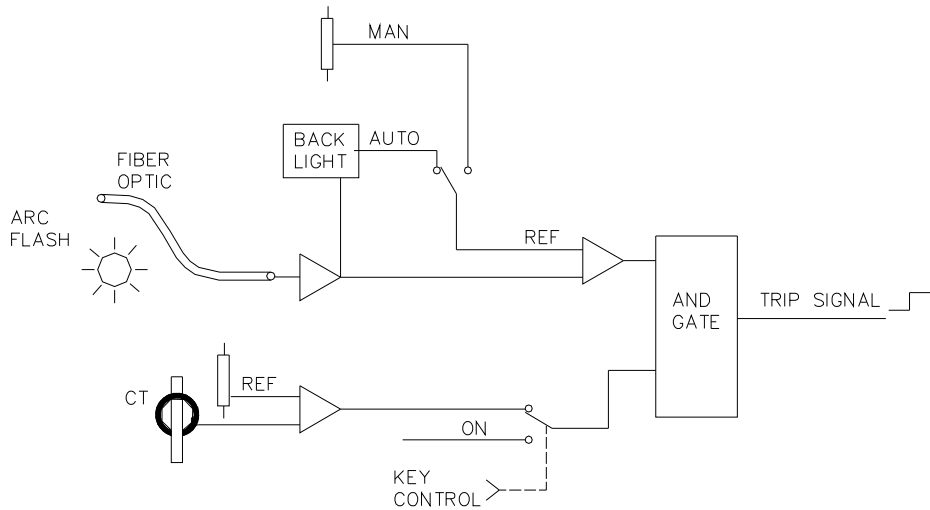

Figure 4.4: Arc Detection Relay Block Diagram

The block diagram shows two high speed solid state relays and one conventional normally-open contact for tripping. The operating times of the solid state and contact tripping times are illustrated below in Figure 4.5.

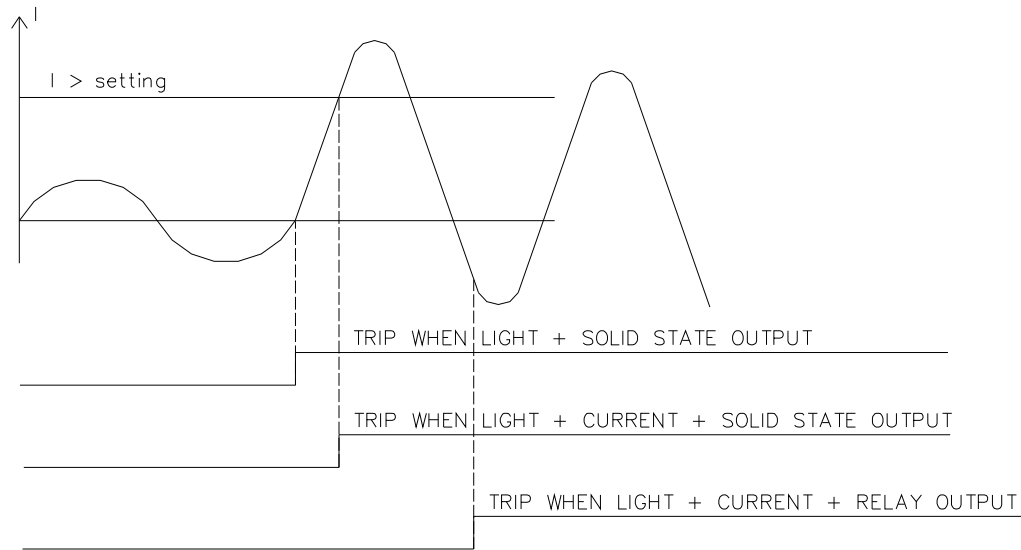

Figure 4.5: Arc Detection Relay Operating Times

The major benefit of using this style of arc flash detection relay is the ability to limit incident energy whether the available fault current is relatively high or low. IEEE 1584 states that the worst case incident energy level may not occur at the bolted fault current point. With the standard protection of time overcurrent and instantaneous protection, low level fault currents can easily result in higher incident energy levels because the clearing time is so much longer [32]. The increased clearing time from a lower amperage fault current can offset the higher amperage from a larger fault current and produce an incident energy that is more hazardous. Once the arcing current exceeds the instantaneous setting, incident energy levels drop dramatically [23]. Figure 4.6 below illustrates this.

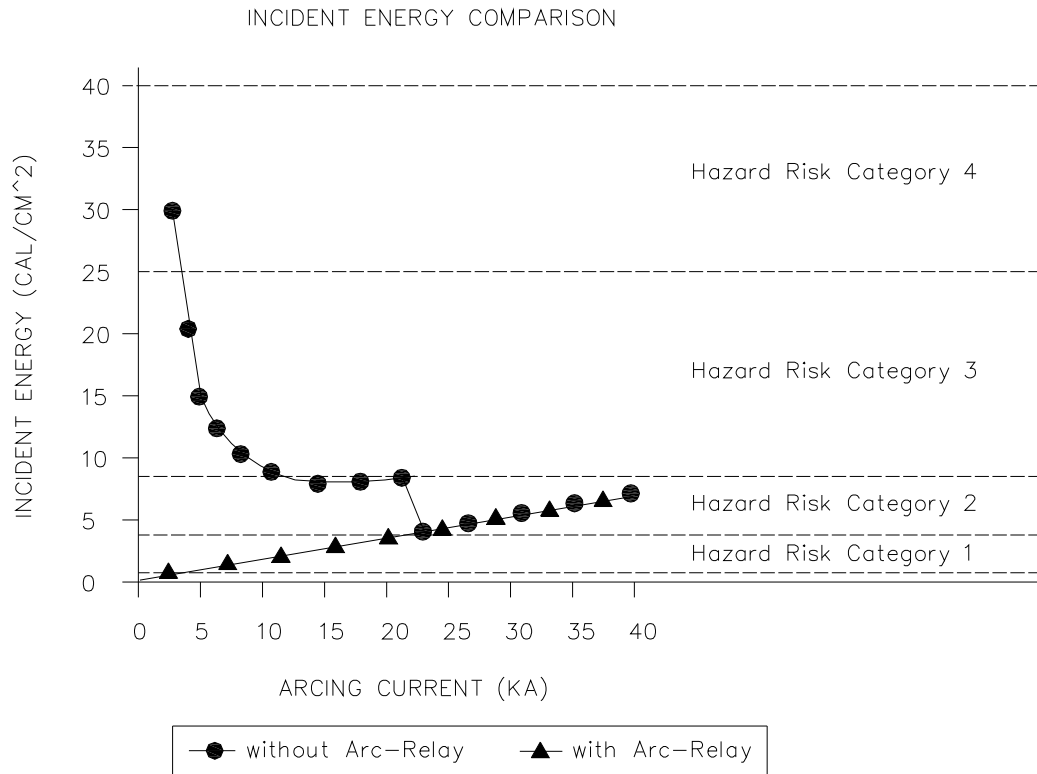

Figure 4.6: Incident Energy Levels With and Without Arc Flash Relay

The arc flash relay is shown to provide instantaneous tripping across all magnitudes of fault current. Because there is no coordination requirement, clearing time is essentially reduced to the operating time of the back-up breaker [23]. This shows the benefit in reducing the clearing time of the arc flash.

A typical single loop example for the fiber optic sensor is shown below in Figure 4-7. In this application the single optical fiber covers four circuit breaker feeder cubicles. When the fault detector pickup threshold is exceeded and an optical arc flash is detected, the arc detection relay will send a trip signal to both the high-side and low-side circuit breakers.

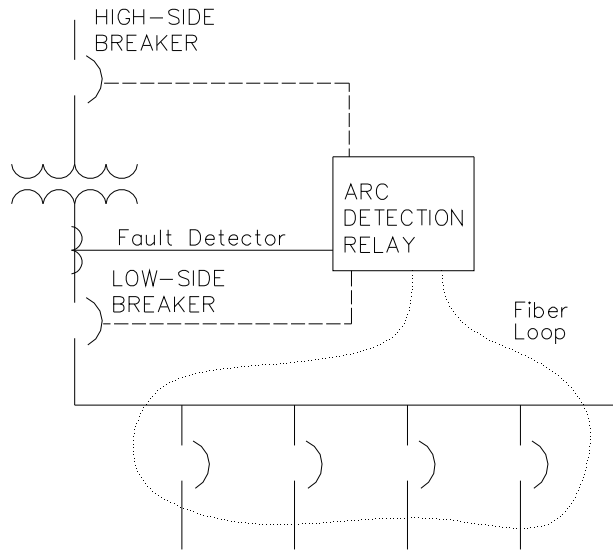

Figure 4.7: Single Fiber Loop Layout

4.6 Allowing a Lack of Circuit Breaker Selectivity

The goal of protective device coordination is to isolate the faulted section of the electrical system and to not interrupt nearby or parallel feeders. This process is accomplished by the setting of protective devices as shown in Chapter 2. However, when protecting the system for arc flash, the isolation of the faulted section must happen as quickly as possible in order to avoid the damage to electrical equipment and maintenance personnel. When a protective device system has been selectively coordinated with the goal of isolating faults, the optimal arc flash protection might not be in place.

Allowing the electrical system to operate with a lack of selective coordination can sometimes decrease the arcing current interruption time and therefore decrease the incident energy. Although the 2008 NEC Article 708 calls for selective coordination in all “Critical Operations Power Systems (COPS), not all electrical systems fall under this

categorization [35]. An example is of a manufacturing facility that produces aluminum siding where the system is not COPS, but the company management has decided not to de-energize for certain types of electrical system maintenance.

5. IMPACT OF ARC FLASH ANALYSIS

This chapter presents the impact of arc flash hazard analysis on existing facilities and the implementation of mitigation techniques with the intent of lowering arc flash hazards. The facilities analyzed are from a database of over one-hundred electrical system studies completed during the last 12 years. The existing electrical systems will be described along with owner's objectives and goals for the arc flash hazard analysis. The study will be performed with the assistance of computer software and the results analyzed and discussed. Methods for mitigating areas of high arc flash hazard will be recommended and then the system will be reevaluated by the computer software.

5.1 Free Standing Ambulatory Surgery Center

This section of the project analyzes a power distribution system located in a free standing ambulatory surgery center located in Pinellas County that was built in 1999. The facility contains approximately 7500 square feet of offices and surgical suites. Per the State of Florida Statutes and the Agency for Healthcare Administration, a fault current study and protective device coordination analysis was required for this facility before a Certificate of Occupancy could be issued. Years after opening, an arc flash hazard analysis was directed by ownership with the intent to comply with OSHA and NFPA. The company goal was to achieve a hazard risk category 3 or below at all electrical breaker panels in the system.

The electrical service entrance is 120/208 volts, 600 amps, 3-phase, 4-wire, grounded Y. The distribution design consists of a main distribution panel (MDP) specified at 800 amp main lug only with 5 feeder breakers serving as the system main disconnects. The system design and installation is acceptable per the National Electrical Code and all applicable building codes. The partial one-line diagram in Figure 5.1 shows this feeder system.

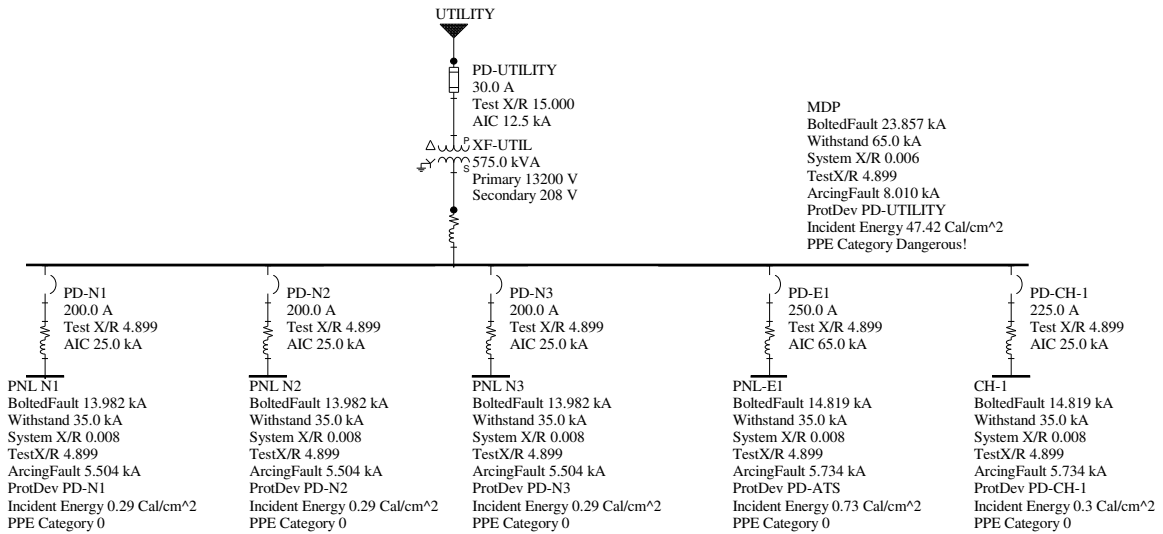

Figure 5.1: One-Line Diagram for Surgery Center

By observing the output results of the computer simulation in Figure 5.1, it is possible to verify the equipment ratings by comparing the system fault current and X/R ratio with the equipment withstand or AIC and tested X/R ratio. This comparison is shown in the equipment evaluation Table 5.1 and each device is shown as a pass or fail based on this criteria. For this electrical system, all devices pass the equipment evaluation for fault current analysis.

Table 5.1 Equipment Evaluation Table for Surgery Center

Device	AFC/Bolted Fault	Withstand/AIC	System X/R	Device Tested X/R	Result
MDP	23.8kA	65kA	0.006	4.8	Pass
PD-N1,2,3	13.9kA	25kA	0.006	4.8	Pass
PD-E1	14.8kA	25kA	0.006	4.8	Pass
PD-CH-1	14.8kA	25kA	0.006	4.8	Pass
PNL-N1,2,3	13.9kA	35kA	0.008	4.8	Pass
PNL-E1	14.8kA	35kA	0.008	4.8	Pass
PNL-CH-1	14.8kA	35kA	0.008	4.8	Pass

After all devices are evaluated per fault current analysis, the system must be analyzed for protective device coordination. Due to the design of this electrical system, the protective device coordination can quickly be tested. Since all feeder breakers are the same size and type, one typical TCC curve showing the selective coordination with the utility fuse is all that is necessary.

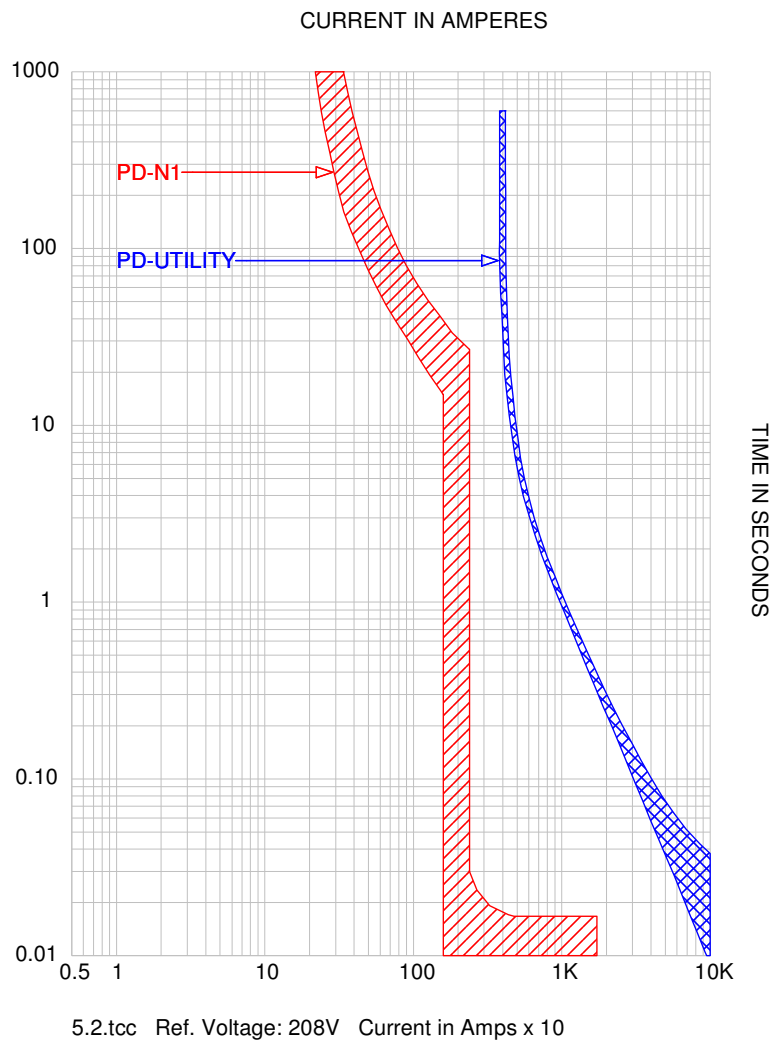

Figure 5.2: TCC Curve for Surgery Center

The time current curves show that there is no overlap of the protective device curves, hence this system is selectively coordinated.

The results of the arc flash hazard analysis are given on the one line diagram. This shows incident energy levels for PNL-N-1,2,3 at 0.29cal/cm^2 , PNL-E1 at 0.73cal/cm^2 , and PNL-CH-1 at 0.3cal/cm^2 which are all hazard risk category 0. A typical time current curve with arcing current and hazard risk categories for these panels is shown below in Figure 5.3.

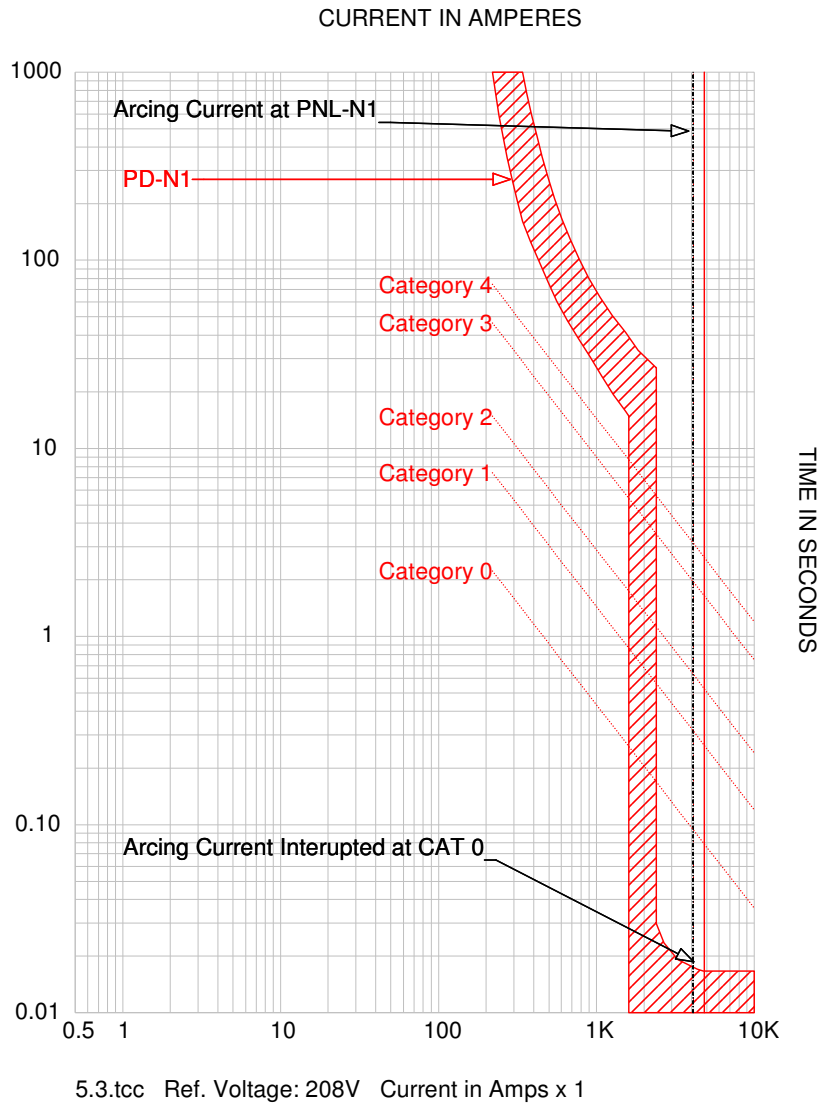

Figure 5.3: Time Current Curve for Arcing Current at PNL-N1

The arc flash hazard analysis for the main distribution panel MDP shows a much more serious situation. The results of the simulation report an incident energy of 47.42cal/cm^2 , which results in a hazard risk category of Dangerous. This is a result of the MDP's primary protective device being the utility fuse PD-Utility. The TCC with arcing current for the MDP is shown below.

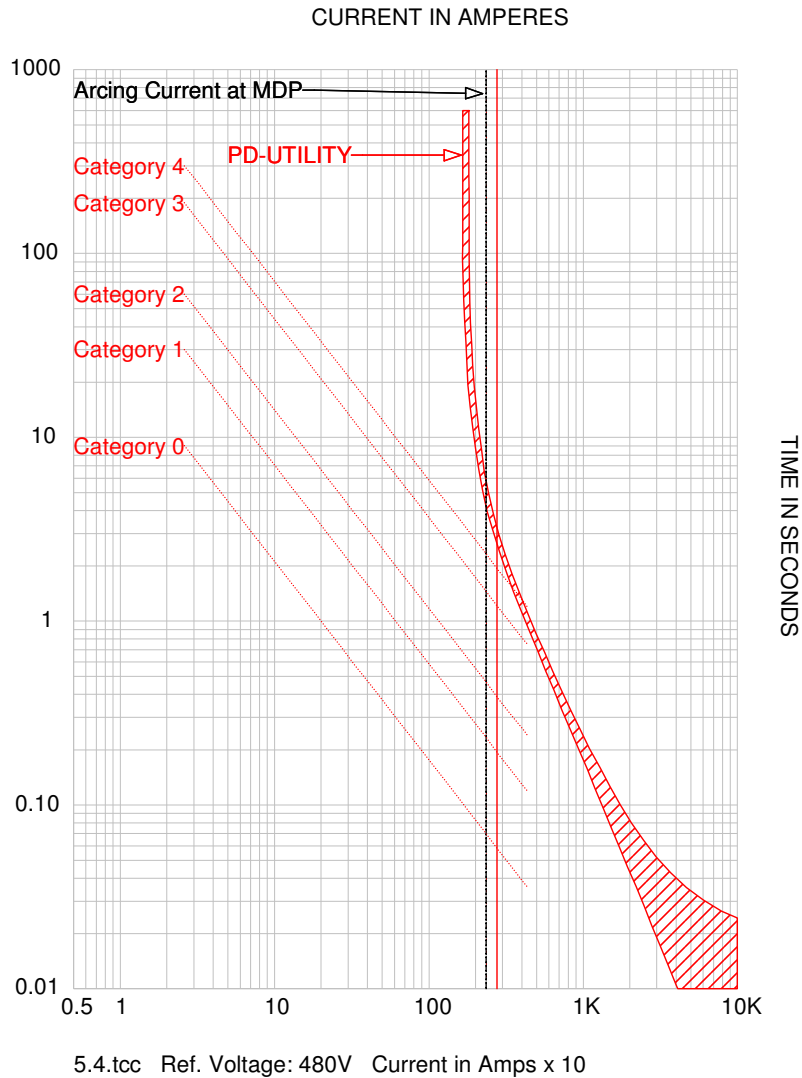

Figure 5.4: Time Current Curve for Arcing Current at MDP

The time current curve for PD-Utility is shown to clear the arcing current at approximately 8 seconds. This results in a hazard risk category of Dangerous.

The next step is to investigate arc flash hazard mitigation techniques for this electrical system. There is one panel that has an incident energy resulting in an unacceptable hazard risk category which is the MDP. The inherent system design and installation does not offer any options to adjust protective device settings with the intent

of protecting the MDP with a quicker interrupt during an arc flash. This electrical system is a candidate for add-on equipment.

A possible solution for this surgery center is to add a main protective device ahead of the MDP. Installing a 600 amp fuse ahead of the MDP, results in the software analysis shown in the one line diagram below in Figure 5.5.

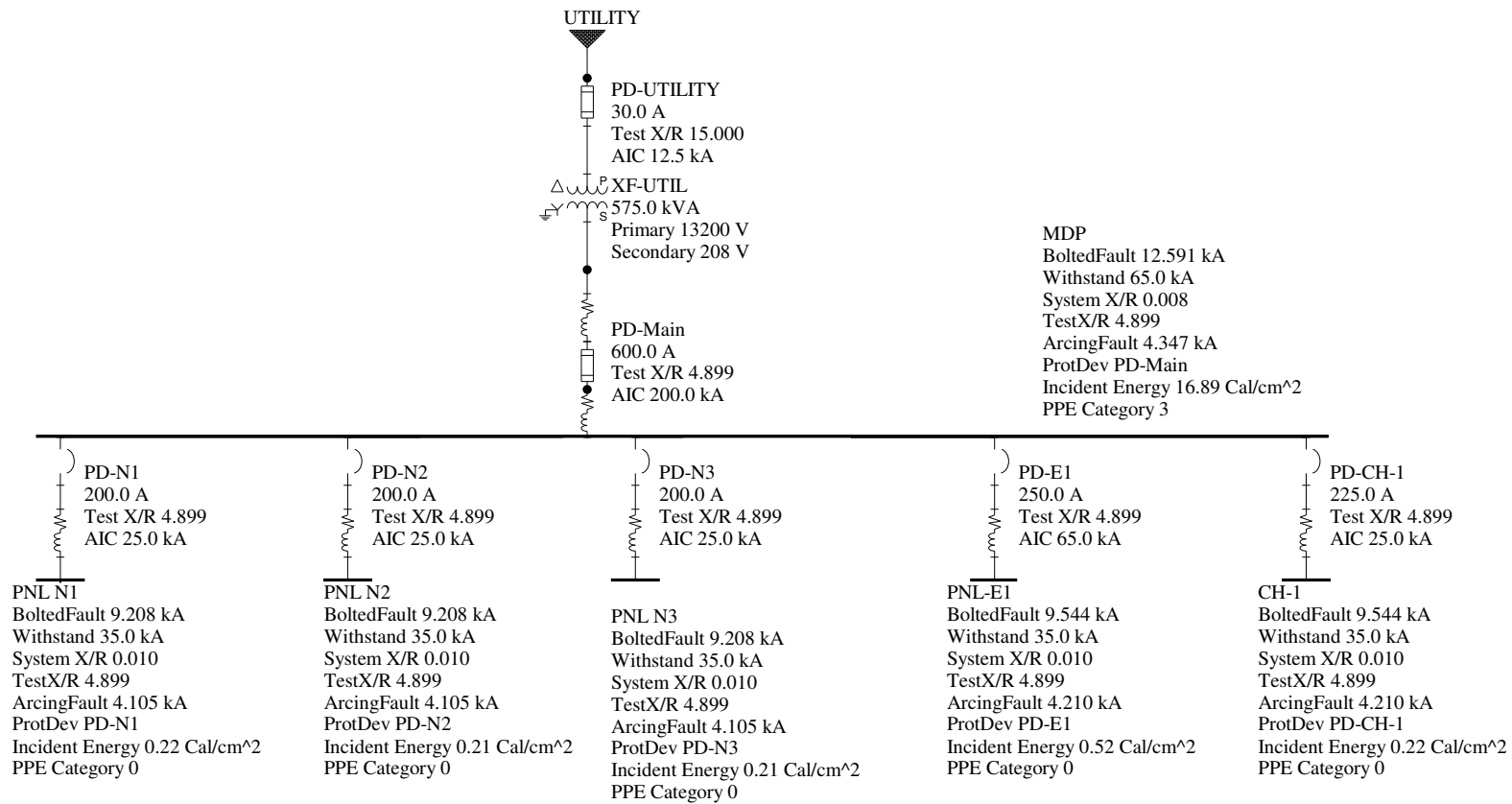

Figure 5.5: One-Line Diagram for Surgery Center with Added Main Fuse

The one line diagram now shows the incident energy at MDP at 16.89cal/cm^2 , which results in a hazard risk category 3. The TCC for this added fuse PD-MAIN is shown below.

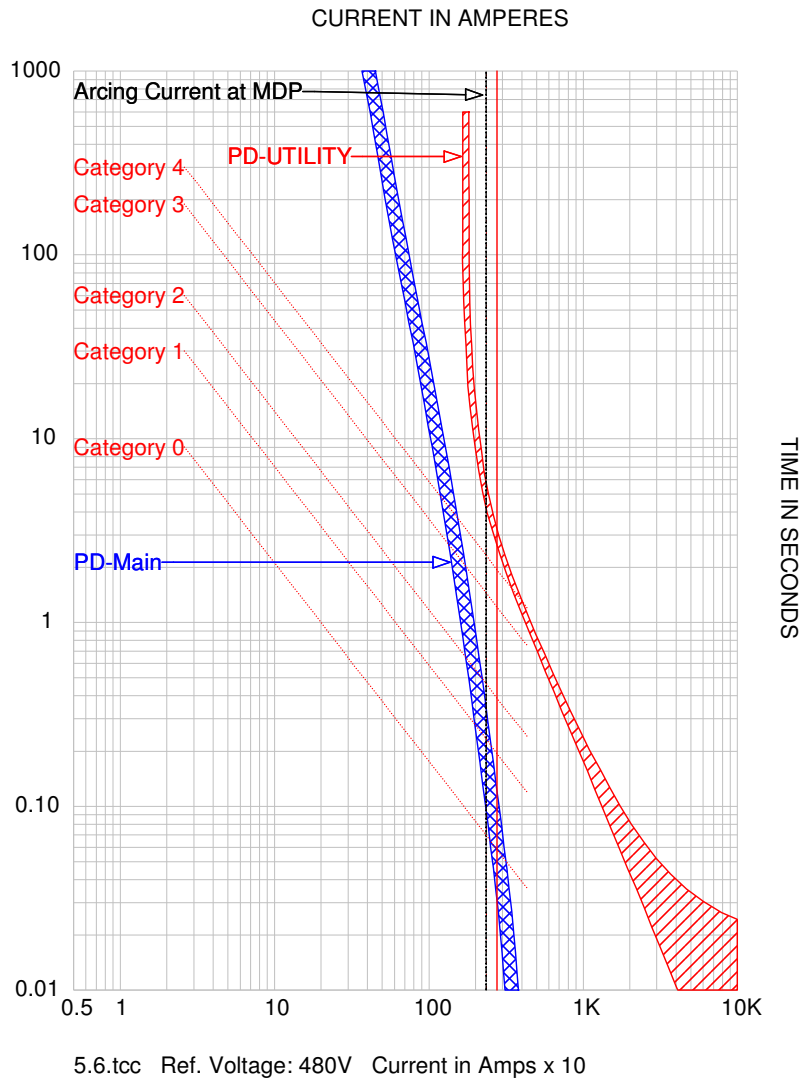

Figure 5.6: TCC for Arcing Current at MDP with Added Fuse

The TCC shows the new main fuse PD-MAIN interrupting the arcing current at approximately 0.4 seconds thus resulting in a hazard risk category 3.

In theory, this is a viable solution. However, implementation this could create a number of serious issues for the facility, including:

1. The electrical service will have to be interrupted for an extended period of time.
2. The existing electrical service conduit and conductors will have to be dug-up and replaced.
3. The expense for this could be large and will have to be budgeted.

There are no other arc-flash mitigation options for the MDP panel of this electrical system. As the system currently operates, they will need to have the power company take them out of service when they maintain the MDP panel.

5.2 Heart Catheterization Center

This section of the project analyzes a power distribution system located in a free standing ambulatory heart catheterization center located in Putnam County, FL that was built in 2001. The facility contains approximately 8100 square feet of offices, exam rooms, and heart catheterization suites. Per the State of Florida Statutes and the Agency for Healthcare Administration, a fault current study and protective device coordination analysis was required for this facility before a Certificate of Occupancy could be issued. Years after opening, an arc flash hazard analysis was directed by ownership with the intent to comply with OSHA and NFPA. The owner's goal was to achieve a hazard risk category 1 or below for all buses and electrical breaker panels in the system.

The electrical service entrance is 277/480 volts, 800 amps, 3-phase, 4-wire, grounded Y. The distribution design consists of a main distribution panel (MDP) specified at 800 amp main circuit breaker with 4 feeder breakers distributing power to distribution panels and transformers. The system design and installation is acceptable per the National Electrical Code and all applicable building codes. The partial one-line diagram in Figure 5.7 shows this electrical system.

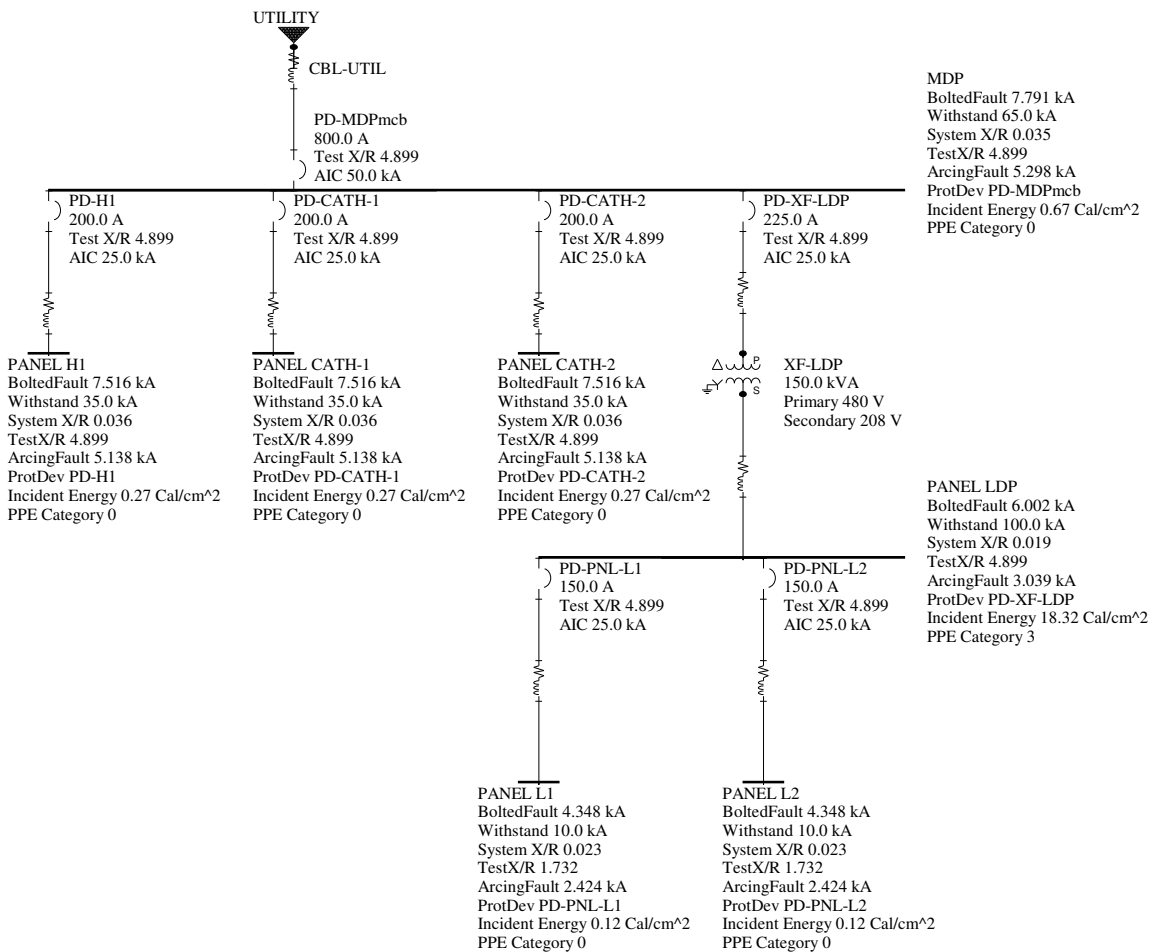

Figure 5.7: One-Line Diagram for Heart Catheterization Lab

From observing the output results of the computer simulation in Figure 5.7, it is possible to verify the equipment ratings by comparing the system fault current and X/R ratio with the equipment withstand or AIC and tested X/R ratio. This comparison is shown in the equipment evaluation Table 5.2 and each device is shown as a pass or fail based on this criteria. For this electrical system all devices pass the equipment evaluation for fault current analysis.

Table 5.2 Equipment Evaluation Table for Heart Catheterization Lab

Device	AFC/Bolte d Fault	Withstand/AI C	System X/R	Device Tested X/R	Result
PD-MDPmcb	7.8kA	50kA	0.035	4.8	Pass
PD-H1,Cath1&2	7.8kA	25kA	0.035	4.8	Pass
PD-XF-LDP	7.8kA	25kA	0.035	4.8	Pass
MDP	7.8kA	65kA	0.035	4.8	Pass
PNL-H1, Cath1&2	7.5kA	35kA	0.036	4.8	Pass
PNL-LDP	6.0kA	100kA	0.019	4.8	Pass
PNL-L1&L2	4.3kA	10kA	0.024	1.7	Pass

Next, the system must be analyzed for protective device coordination. Due to the design of this electrical system, the protective device coordination can quickly be tested. Following the largest feeder breaker in each leg allows for one TCC diagram to show selective coordination.

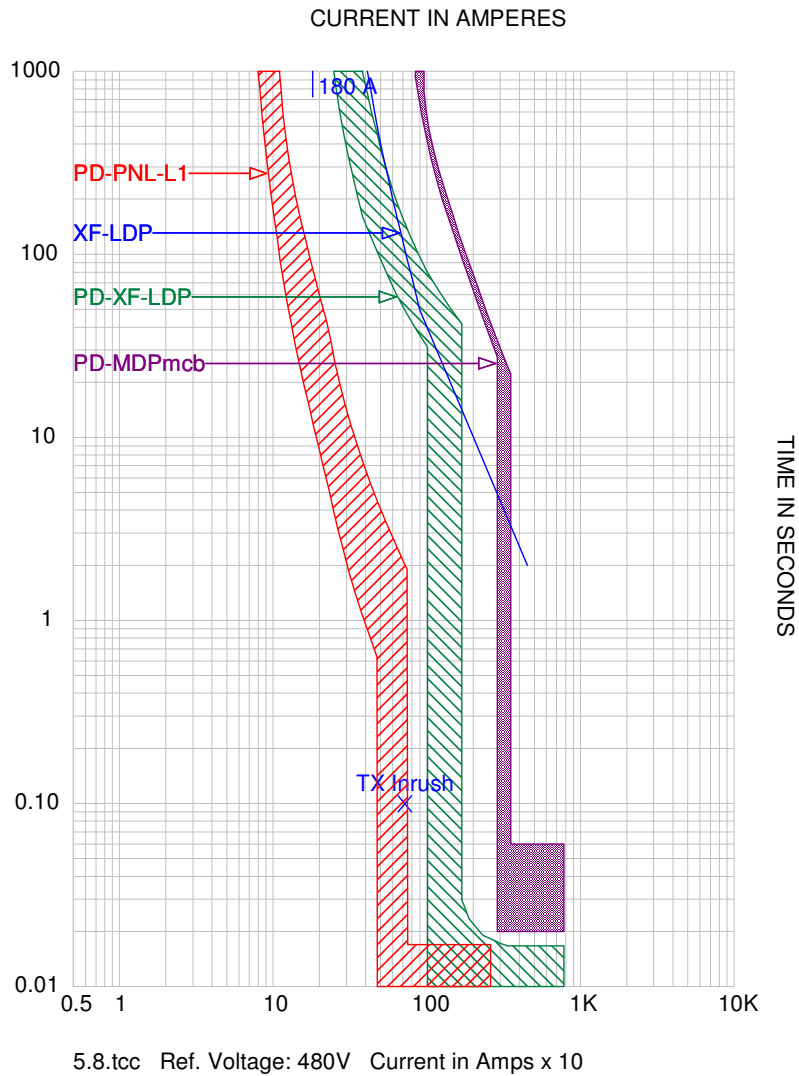

Figure 5.8: TCC Curve for Heart Catheterization Lab

The time current curve for the heart catheterization lab shows that there is no overlap of the protective devices, hence this system is selectively coordinated.

The results of the arc flash hazard analysis are given on the one line diagram. This shows incident energy levels for MDP at 0.67cal/cm^2 , Panels-H1, Cath1&2 at 0.27cal/cm^2 , and Panels-L1&2 at 0.12cal/cm^2 which are all hazard risk category 0. A

typical time current curve with arcing current and hazard risk categories for these panels is shown below in Figure 5.9.

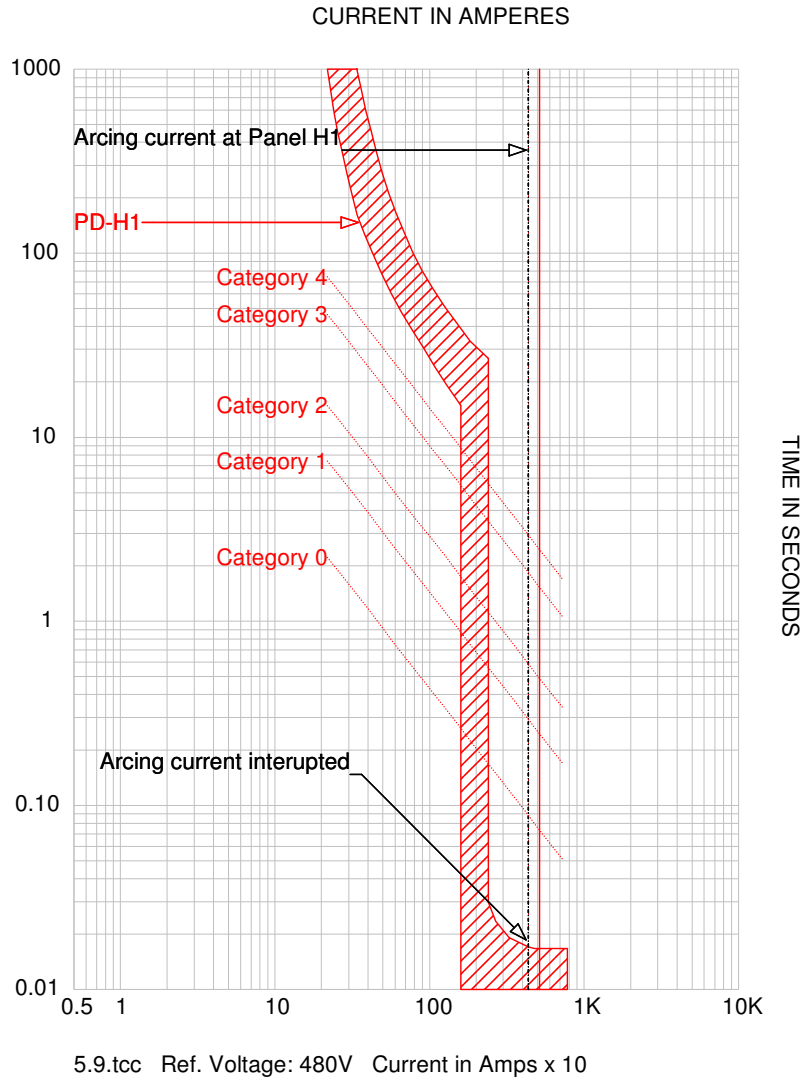

Figure 5.9: Time Current Curve for Arcing Current at Panel H1

The arc flash hazard analysis for the Panel LDP shows a much more hazardous situation. The results of the simulation report an incident energy of 18.32cal/cm^2 which results in a hazard risk Category 3. This is a result of the transformer XF-LDP primary protective device being the thermal magnetic breaker PD-XF-LDP. The TCC with arcing current for the Panel LDP is shown below.

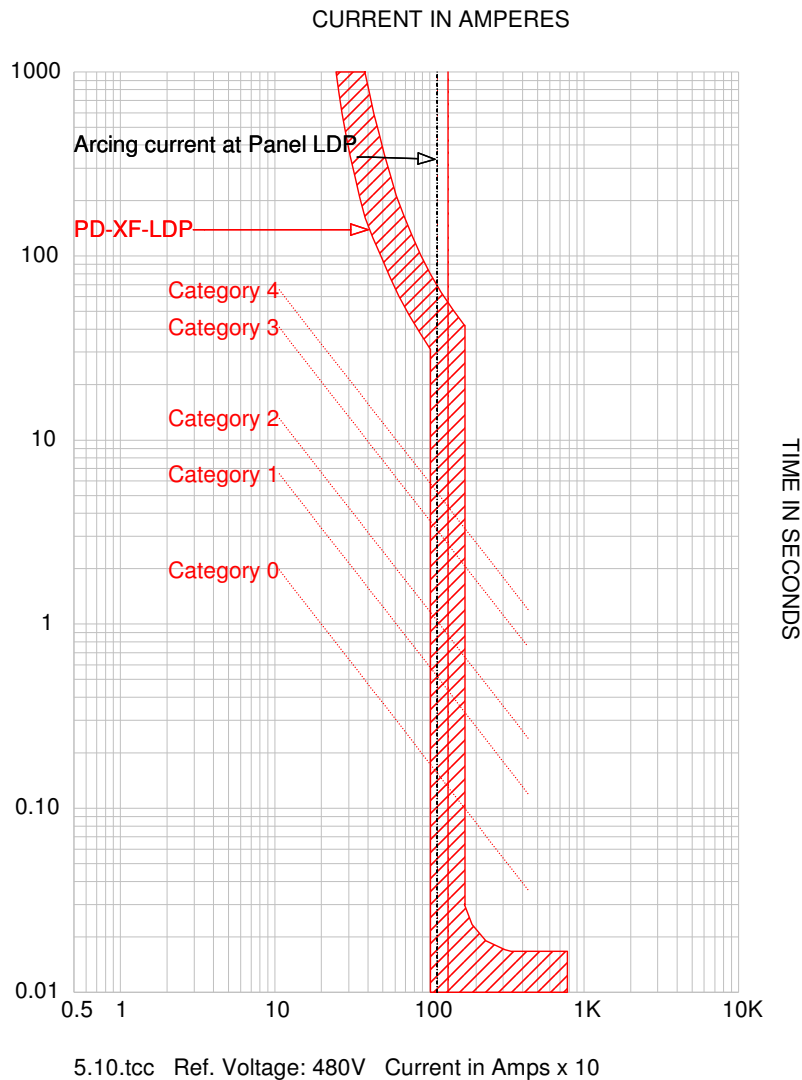

Figure 5.10: Time Current Curve for Arcing Current at Panel LDP

Figure 5.10 shows the time current curve for PD-XF-LDP clearing the arcing current at approximately 8 seconds. However, due to research results and the guidelines of IEEE 1584, the analysis will limit the arcing duration at 2 seconds and calculate the incident energy then. This results in a hazard risk of Category 3.

The next step is to investigate arc flash hazard mitigation techniques for this electrical system. There is one panel that has an incident energy resulting in an unacceptable hazard risk category which is Panel LDP. The protection device for this

panel is a thermal magnetic breaker and the instantaneous adjustment does not offer enough flexibility to interrupt the arcing current at a shorter duration.

A possible solution for this heart catheterization lab is to replace the thermal magnetic breaker with a more flexible LSI style device. By installing a 225 amp LSI adjustable breaker to protect the transformer XF-LDP, the system gets the results shown in the software analysis below.

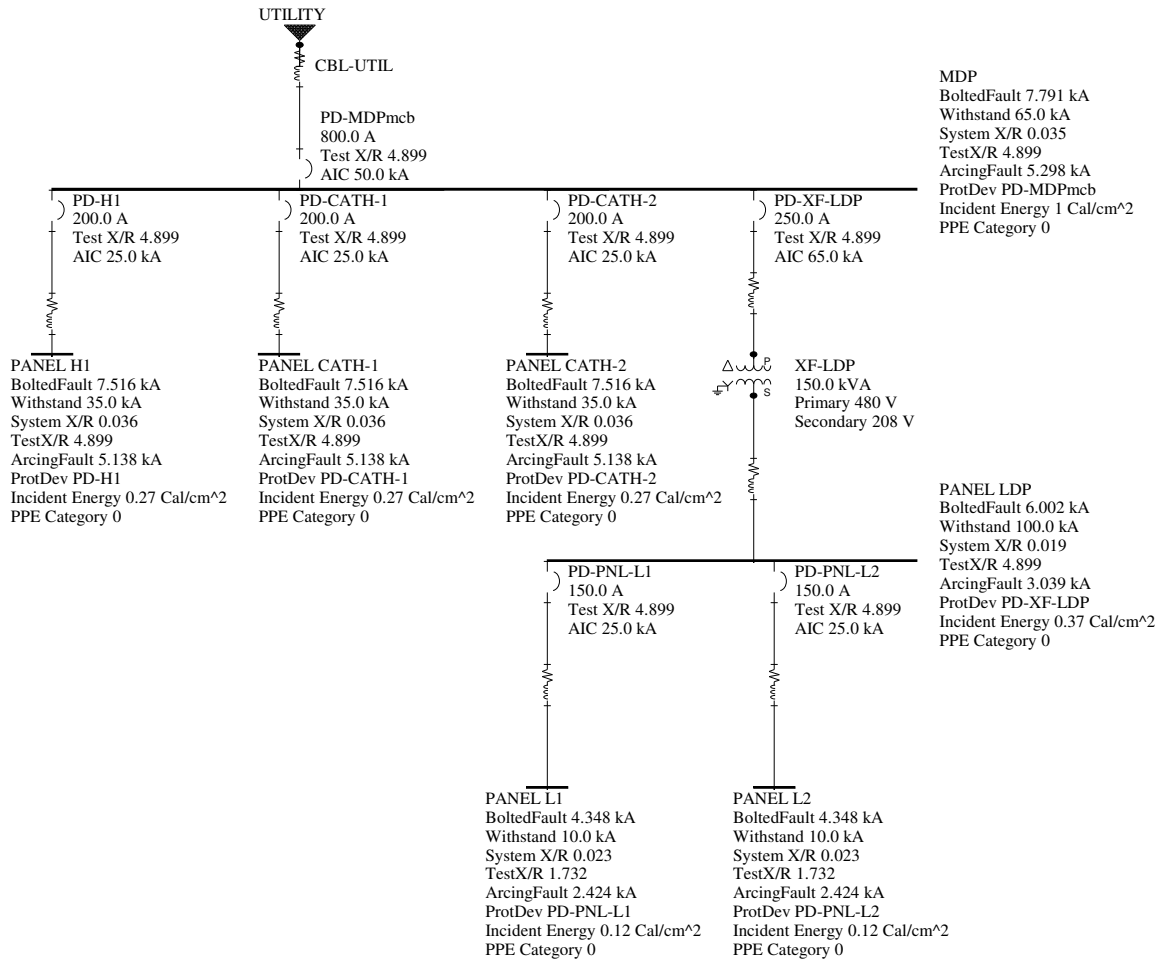

Figure 5.11: One-Line Diagram for Surgery Center with Added Main Breaker

The one line diagram in Figure 5.11 now shows the incident energy at Panel LDP at 0.37cal/cm^2 , which results in a hazard risk category 0. The TCC for this changed PD-XFV-LDP is shown below in Figure 5.12. The arcing current is now interrupted at approximately 0.085 seconds thus lowering the arc flash hazard.

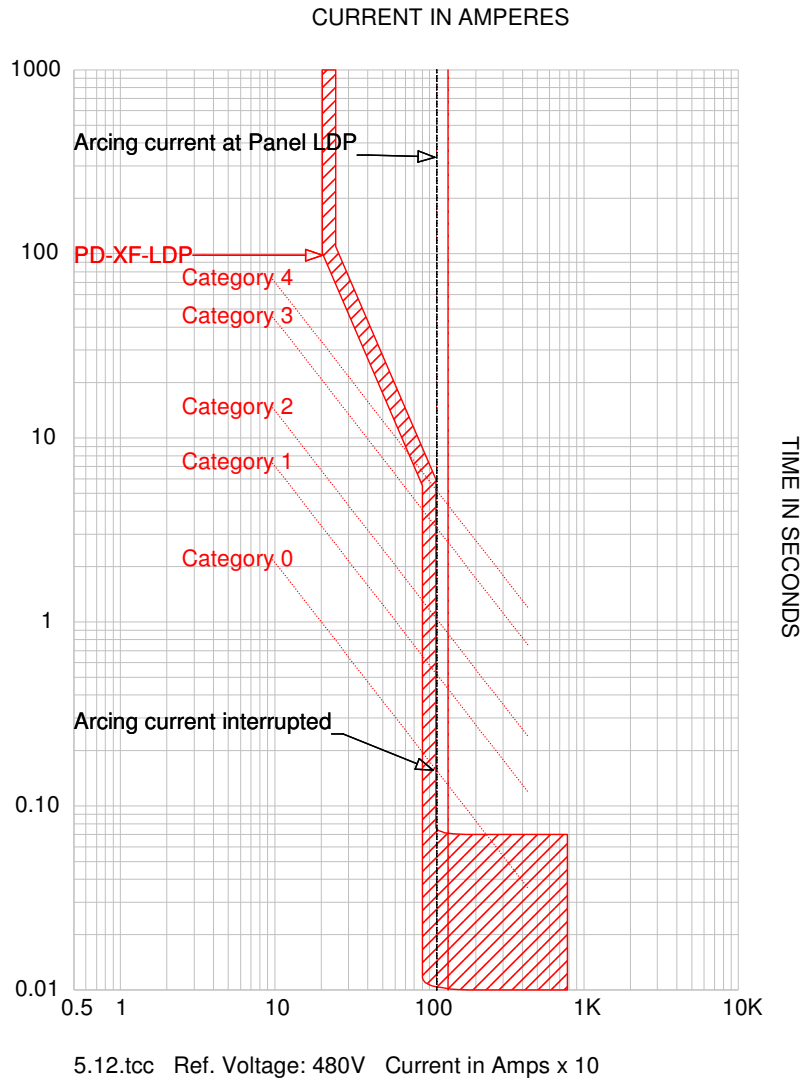
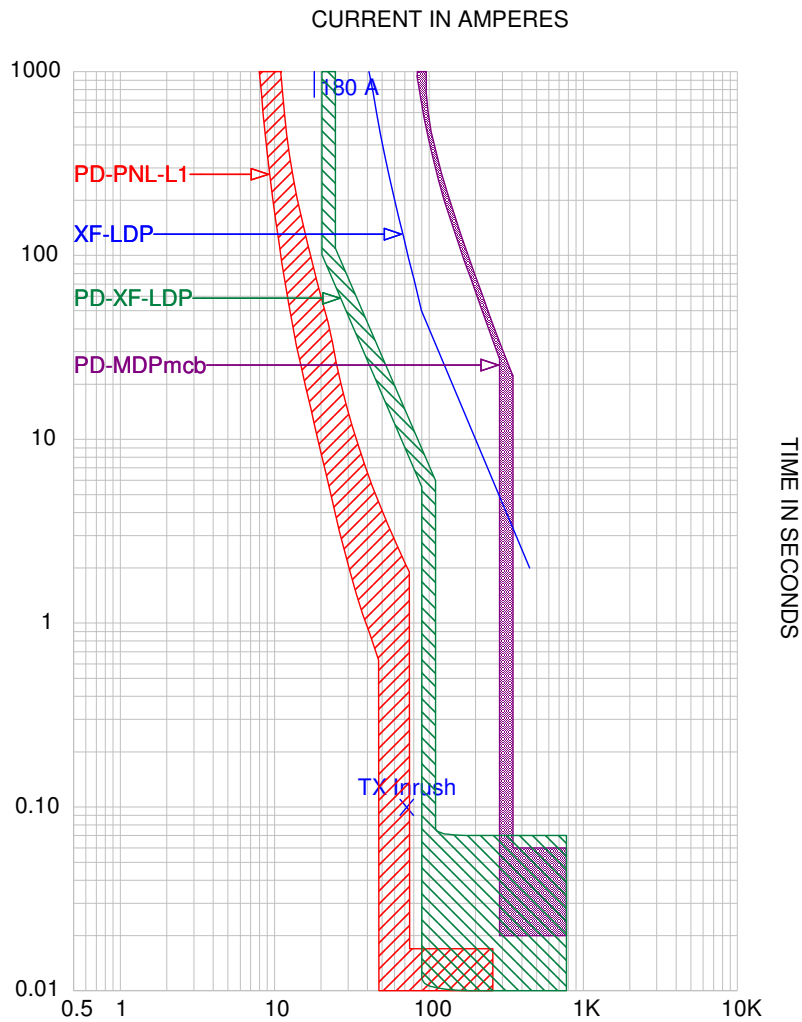

Figure 5.12: TCC for Arcing Current at Panel LDP with LSI Breaker

It is important to check with the series breakers for verification that selective coordination still exists with the new LSI circuit breaker. This is accomplished by plotting the upstream and downstream breakers with the new settings of PD-XF-LP. These circuit breakers are shown to be selectively coordinated in Figure 5.13.



5.13.tcc Ref. Voltage: 480V Current in Amps x 10

Figure 5.13: TCC for Heart Catheterization Lab after Breaker Change

5.3 Metal Container Manufacturer

This section of the project analyzes a power distribution system located in a metal container manufacturing plant located in Hillsborough County that was originally constructed in the 1970s. The facility is approximately 2500 square feet of offices and 175,000 square feet of manufacturing. An arc flash hazard analysis was directed by upper management with the intent to comply with OSHA and NFPA 70E. The corporate goal was to achieve a hazard risk category 1 or below at all points in the system.

The electrical service entrance is 13.2kV at 2500 amps with step down transformers to 277/480 volts, 3-phase, grounded Y. The distribution design consists of an entrance switchboard with four feeder breakers serving the manufacturing sections of the factory. Each quadrant consists of an LSI circuit breaker serving a continuous bus duct with fused bus-taps serving the subsequent bus duct. The partial one-line diagram in Figure 5.14 shows this feeder system.

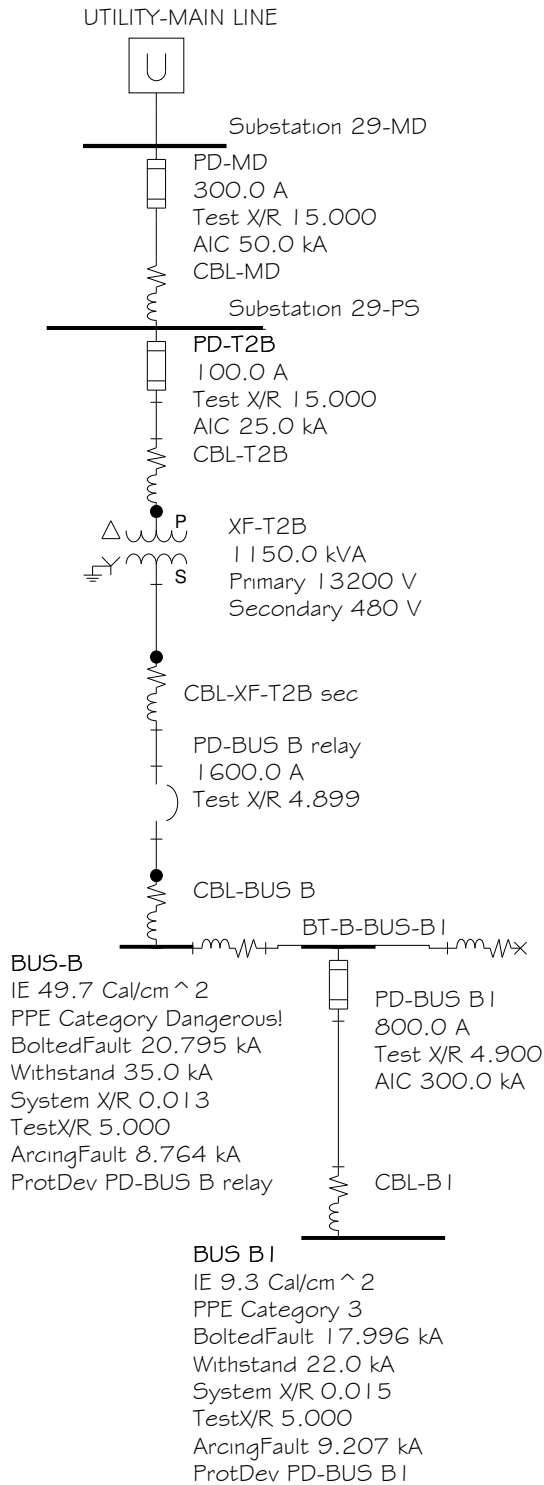

Figure 5.14: Partial One-Line Diagram for Bus Duct Feeder

From observing the output results of the computer simulation in Figure 5.14, it is possible to verify the equipment ratings by comparing the system fault current and X/R ratio with the equipment withstand or AIC and tested X/R ratio. This comparison is shown in the equipment evaluation Table 5.3 and each device is shown as a pass or fail based on this criteria. For this portion of this electrical system all devices are shown to be acceptable based on fault current analysis.

Table 5.3 Equipment Evaluation Table for Bus Duct Feeder

Device	AFC	Withstand/AIC	System X/R	Device Tested X/R	Result
Bus-B	20.7kA	35kA	0.013	5.0	Pass
Bus-B1	17.9kA	22kA	0.015	4.9	Pass
PD-Bus-B1	17.9kA	300kA	0.015	5.0	Pass

After all devices are evaluated per fault current analysis, the system must be analyzed for protective device coordination. The time current curves for PD-Bus-B and PD-Bus-B1 are shown below in Figure 5.15.

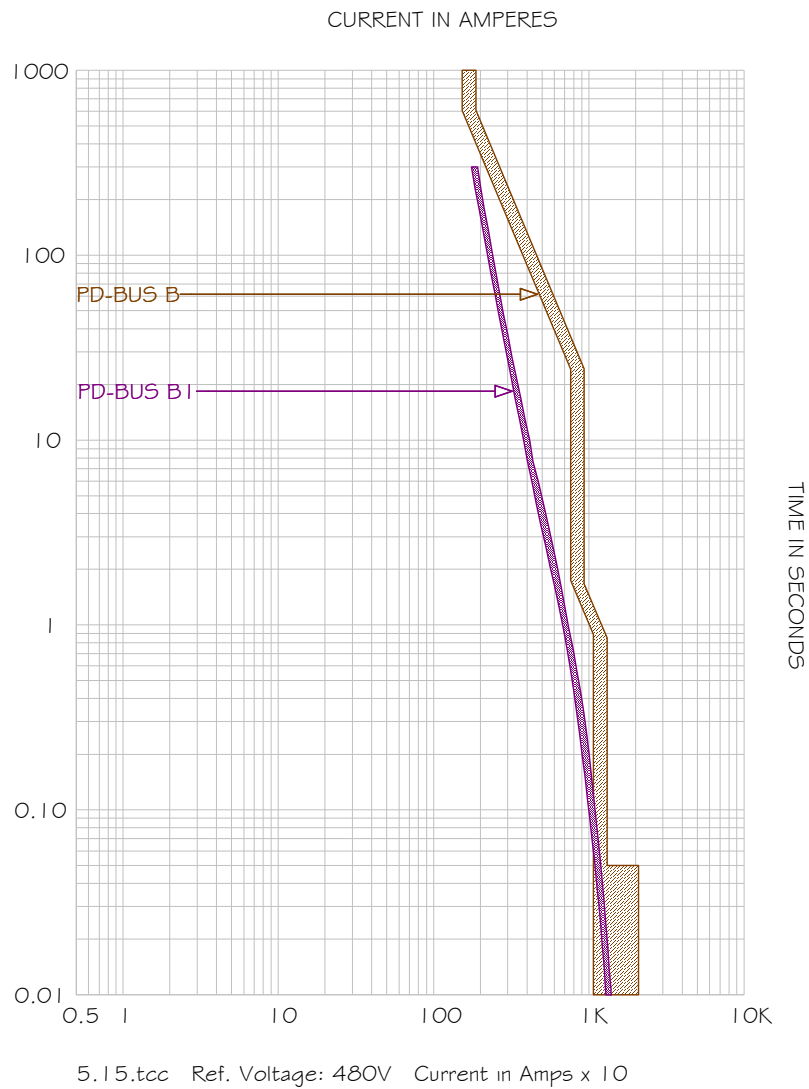

Figure 5.15: TCC PD-Bus-B and PD-Bus-B1

The time current curves show that although there is some overlap of the protective device curves, selective coordination with these devices does exist because the fuse PD-Bus-B1 will melt before the tripping of circuit breaker PD-Bus-B.

The results of the arc flash hazard analysis are given on the partial one line diagram. This shows incident energy levels for Bus-B and Bus-B1 at 49.7cal/cm^2 and 19.3cal/cm^2 respectively, resulting in hazard risk category Dangerous and 3. The time current curves with arcing current and hazard risk categories for Bus-B and Bus-B1 are shown below in Figures 5.16 and 5.17.

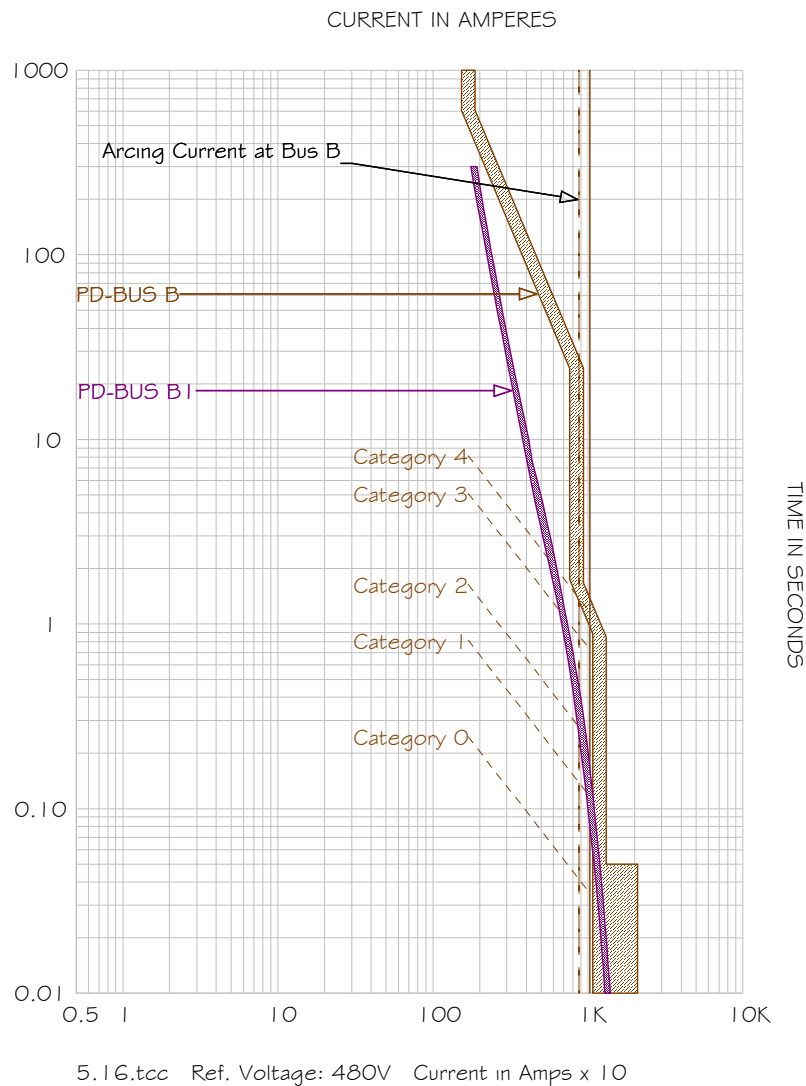

Figure 5.16: Time Current Curve for Arcing Current at Bus-B

The time current curve for PD-Bus-B relay is shown to clear the arcing current at well beyond 10 seconds. This results in a hazard risk category of Dangerous.

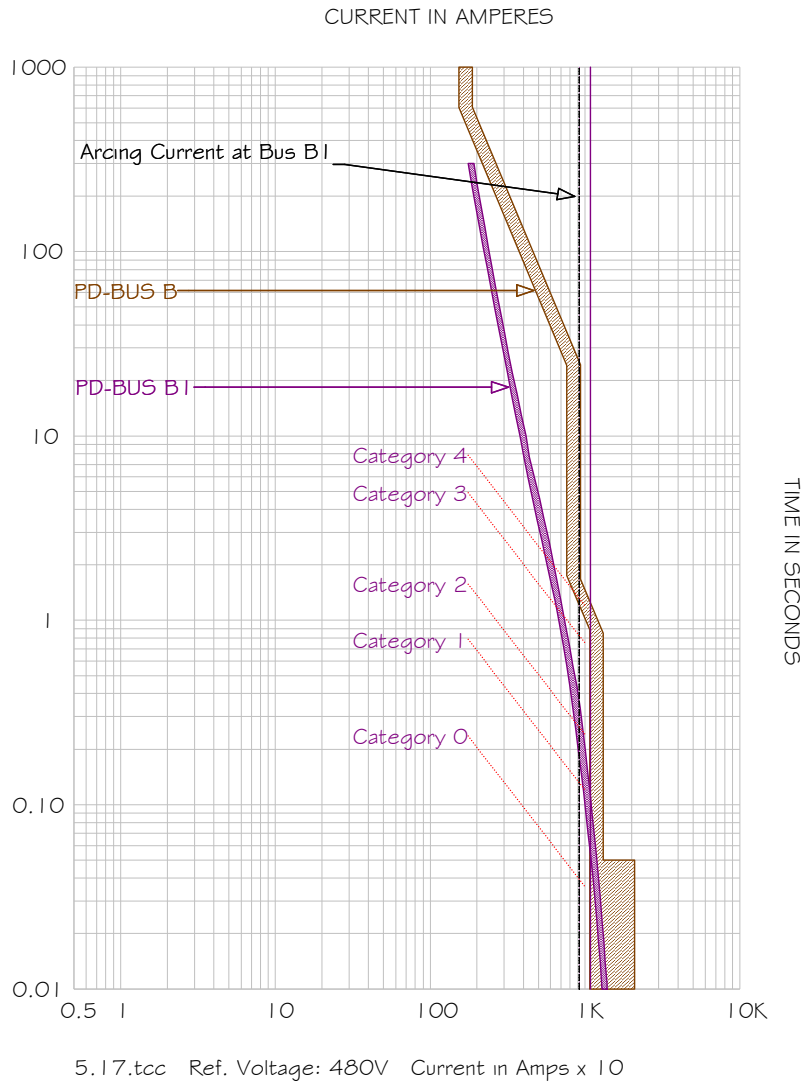

Figure 5.17: Time Current Curve for Arcing Current at Bus-B1

The time current curve for PD-Bus-B1 is shown to clear the arcing current at approximately 0.45 seconds. This results in a hazard risk category of 3.

The next step is to investigate arc flash hazard mitigation techniques for this section of the electrical system. We have two protective devices in the fuse PD-Bus1 and

the adjustable LSI breaker PD-Bus B relay. This is good news for Bus B because the settings of the PD-Bus B relay can be adjusted downward to interrupt the arcing current quicker. At the same time our protection options for Bus B1 are limited because there are no possible adjustments for the fuse interrupting the arcing current there. However, Bus B1 can be better protected by adjusting the PD-Bus B relay below the fuse melting point. This is developing into a classic case of allowing for dis-coordination. The partial one-line diagram if Figure 5.18 shows the results of this implementation.

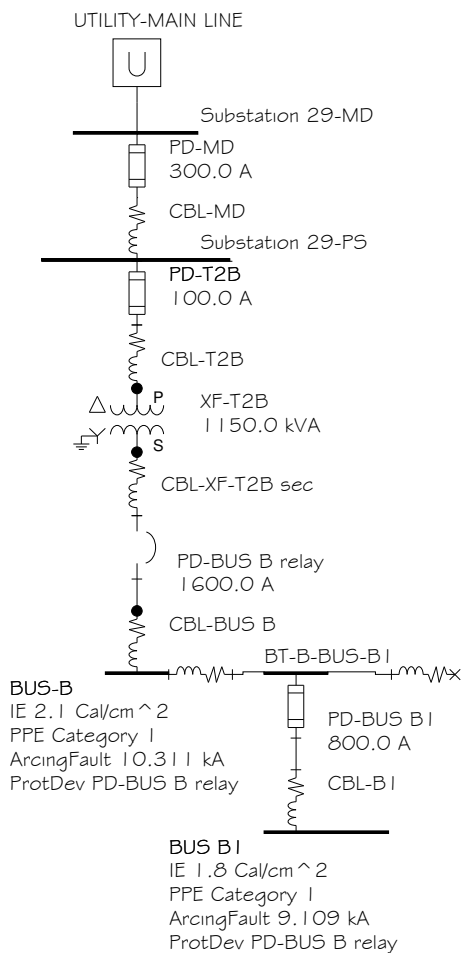

Figure 5.18: Partial One-Line Diagram after Implementation of Dis-Coordinated Settings

The results of the arc flash hazard analysis after adjusting PD-Bus B are given on the partial one line diagram in Figure 5.18. This shows incident energy levels for Bus-B and Bus-B1 decreased to 2.1cal/cm^2 and 1.8cal/cm^2 respectively, resulting in hazard risk category 1 for both buses. The time current curves with arcing current and hazard risk categories for Bus-B and Bus-B1 are shown below in Figures 5.19 and 5.20.

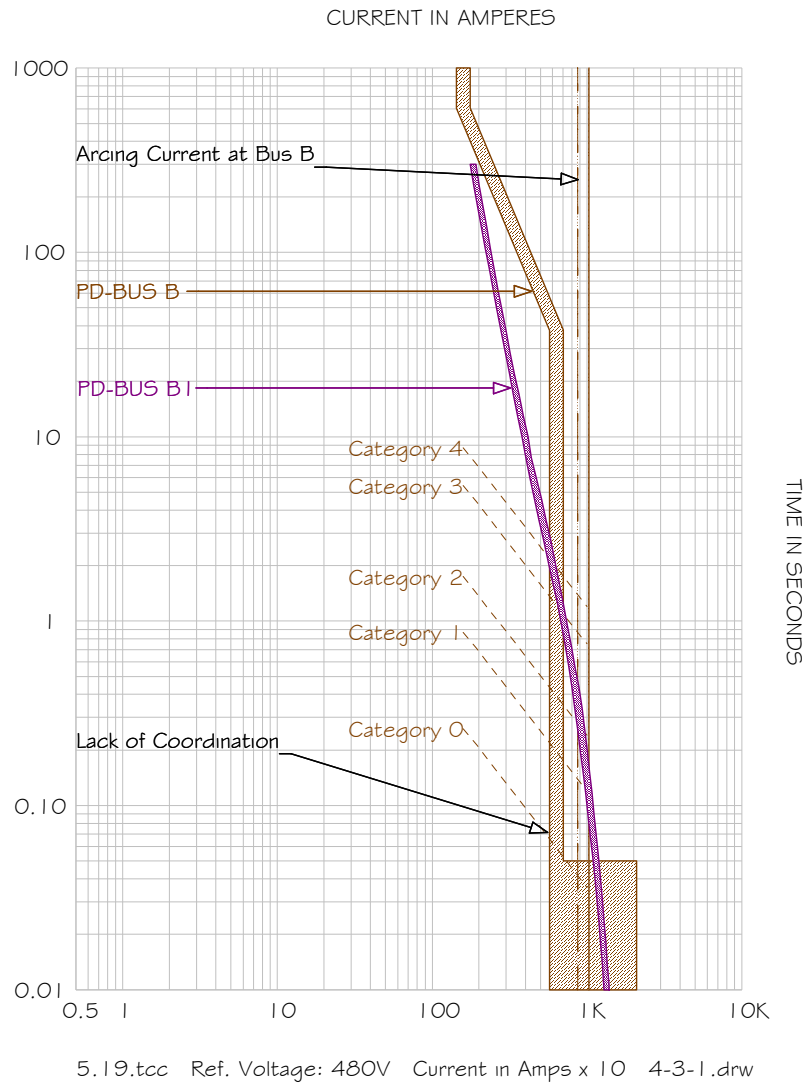

Figure 5.19: TCC for Arcing Current at Bus-B after Breaker Adjustment

The time current curve for PD-Bus-B in Figure 5.19 is shown to clear the arcing current at Bus B in approximately 0.05 seconds. This results in a hazard risk category rating of 1.

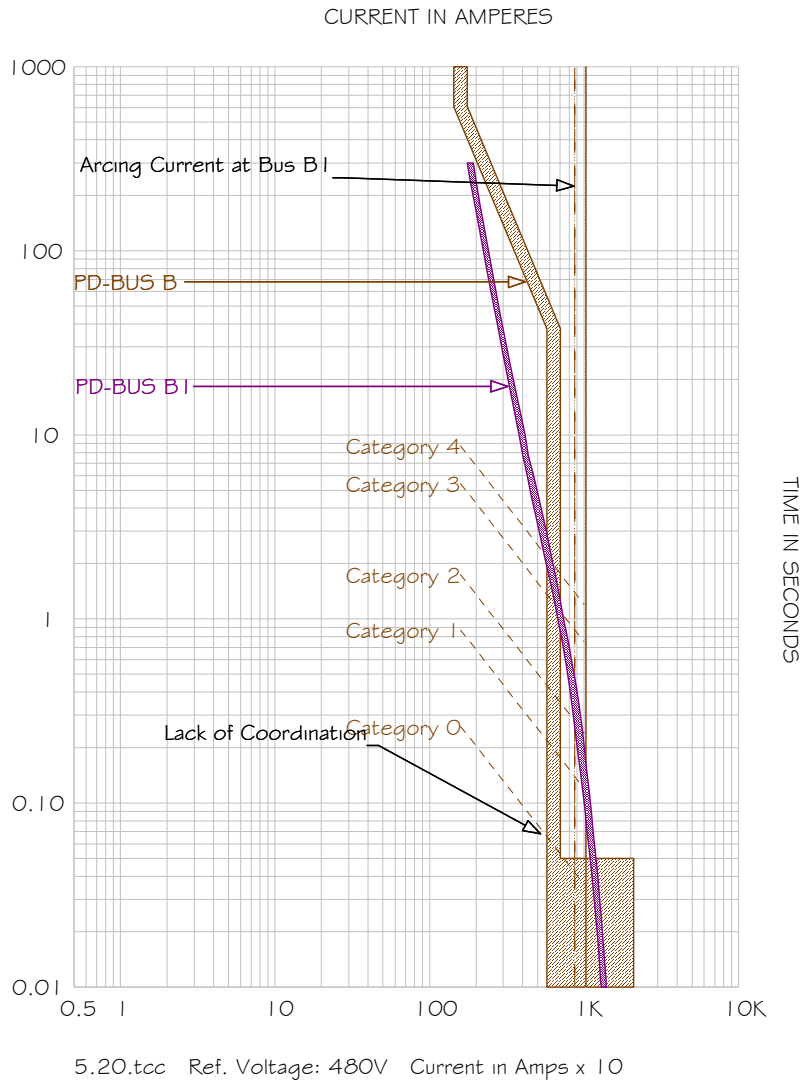

Figure 5.20: TCC for Arcing Current at Bus-B1 after Breaker Adjustment

The time current curve for PD-Bus-B in Figure 5.20 is shown to clear the arcing current at Bus B1 in approximately 0.05 seconds. This results in an arc flash hazard risk category of 1.

This chapter has taken actual electrical power systems and analyzed them for short circuit, protective device coordination, and arc flash hazard. The results have shown that some existing electrical systems have been designed and constructed with inherent properties that often create a high arc flash hazard. The arc flash hazards in these existing systems were mitigated using after-market products and techniques that can be costly and sometimes leave the system to operate in a less than ideal condition. It is important to investigate ways to mitigate the arc flash hazard during the design phase of the project because additional expense and dangerous conditions can be avoided.

6. IMPLEMENTATION OF DESIGN METHODS FOR ARC FLASH MITIGATION

The previous chapters of this dissertation have focused on background information important to understanding the arc flash hazard. Those chapters also detailed the methods for analyzing an electrical system and the process that must occur in order to calculate the arc flash hazard exposure of a technician performing work on energized electrical devices. The research completed in this dissertation focused on the recommended design practices that should be implemented with the goal of mitigating the arc flash hazard before an electrical system is constructed.

This chapter highlights techniques developed by the researcher to be implemented during the design phase of electrical distribution systems that will help mitigate arc flash hazard exposure. These techniques were extracted from a database of over three hundred case studies. The case study projects were all designed by licensed professional engineers over the last 21 years. The analysis of the case studies has led to these techniques. For each case study presented a 480 volt electrical system that is in compliance with the NEC and acceptable for an electrical building permit is the starting point. The arc flash analysis is then performed on the system giving an incident energy level and hazard category. Recommendations for arc flash hazard mitigation to the design of the system are made and a recalculation of the arc flash hazard performed. The implemented design recommendations will show a decreased arc flash hazard incident energy and hazard risk category.

The following sections show that NEC acceptable design strategies can be altered to include the safety concerns of NFPA 70E and therefore will minimize the arc flash hazard exposure. This is specifically evident in the following areas:

1. When applying the National Electric Code, Article 230, Part VI, always specify a single main circuit breaker for building shutdown.
2. At the electrical service entrance the design shall specify enclosed low voltage power circuit breakers in place of fused disconnects.
3. Specify adjustable low voltage power circuit Breakers for protection of step-down transformers rated above 125kVA.
4. Step-Down Transformers larger than 125kVA shall be replaced with a design having two smaller transformers.

6.1 When Applying the National Electric Code, Article 230, Part VI, Always Specify a Single Main Circuit Breaker for Building Shutdown

There are several important factors that need to be included in the decisions made during the design of the electrical service entrance and main distribution panel. The service entrance must meet all NEC requirements for system shutdown and electrical protection. The main distribution panel must be properly sized to carry the facility demand load to avoid an overcurrent situation. The main distribution panel and the protective devices installed inside it must be braced to withstand the available fault current imposed during a short circuit. Furthermore, the main breakers and feeder breakers in the main distribution panel must coordinate with each other and downstream devices to ensure proper isolation of short circuits within the system. In mission critical

facilities the main distribution panel must be properly maintained and therefore the arc flash hazard at this location is important.

The National Electrical Code, Article 230, Part VI addresses building main shut down and disconnect requirements. This part of the code states that an electrical service may be shut down by a maximum of six grouped devices. These devices can be circuit breakers, fused switches, or disconnect switches. This is often accomplished by having a main panel with no main circuit breaker and a maximum of six feeder breakers. A one-line diagram of this scenario is shown in Figure 6.1. This installation is acceptable by the NEC and is a typical installation found in 480 volt electrical distribution systems.

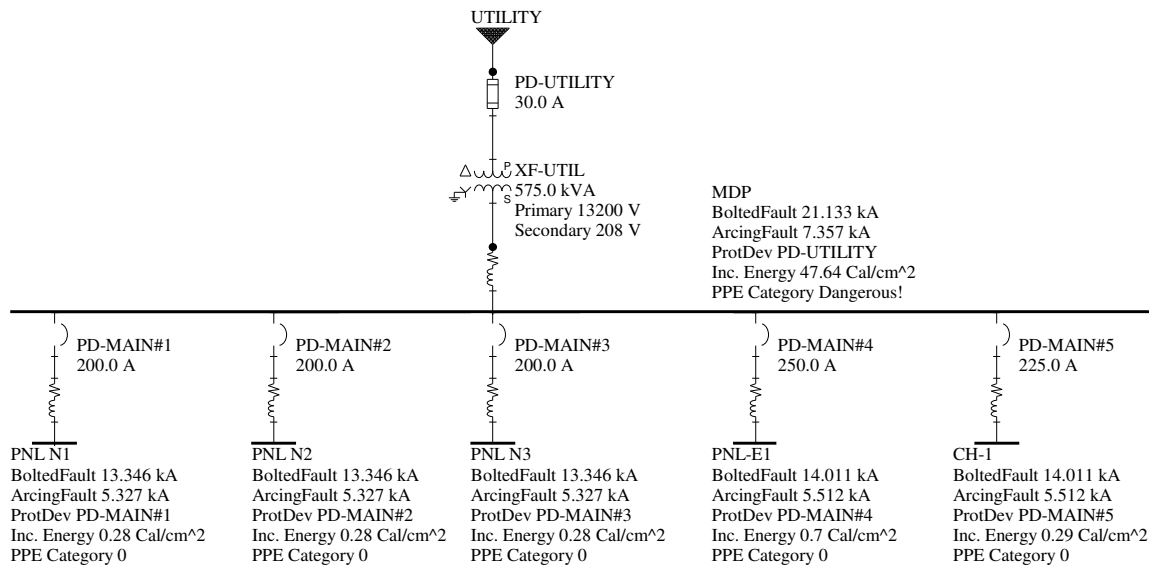

Figure 6.1: Partial One-Line Diagram with 6-Hand Rule in Use

The simulation in Figure 6.1 shows a utility serving a main distribution panel MDP. This MDP is constructed with no main circuit breaker and five feeder breakers denoted PD-MAIN#1-5. In this state the five feeder breakers are acceptable for use as the building disconnecting means per NEC, 230, Part VI.

The simulation shows the fault current of the MDP calculated at 21.13kA, which can be considered a moderate level. The arcing current is shown to be 7.35kA and is a reasonable level for this type of facility. However, the arc flash hazard for this type of installation is very high because the only protective device for the main panel (MDP) is the utility fuse on the primary side of the service transformer. Figure 6.1 shows an incident energy of 47.64 cal/cm² at the MDP, which corresponds to a PPE Category of Dangerous.

Studying the service entrance from a time current analysis gives another perspective. The TCC is plotted in Figure 6.2 and this shows the utility fuse (PD-UTIL) interrupting the arcing current beyond 10 seconds thus justifying the high exposure. The hazard risk category lines are superimposed on the TCC allowing us to see the justification for this scenario having a hazard risk category of Dangerous.

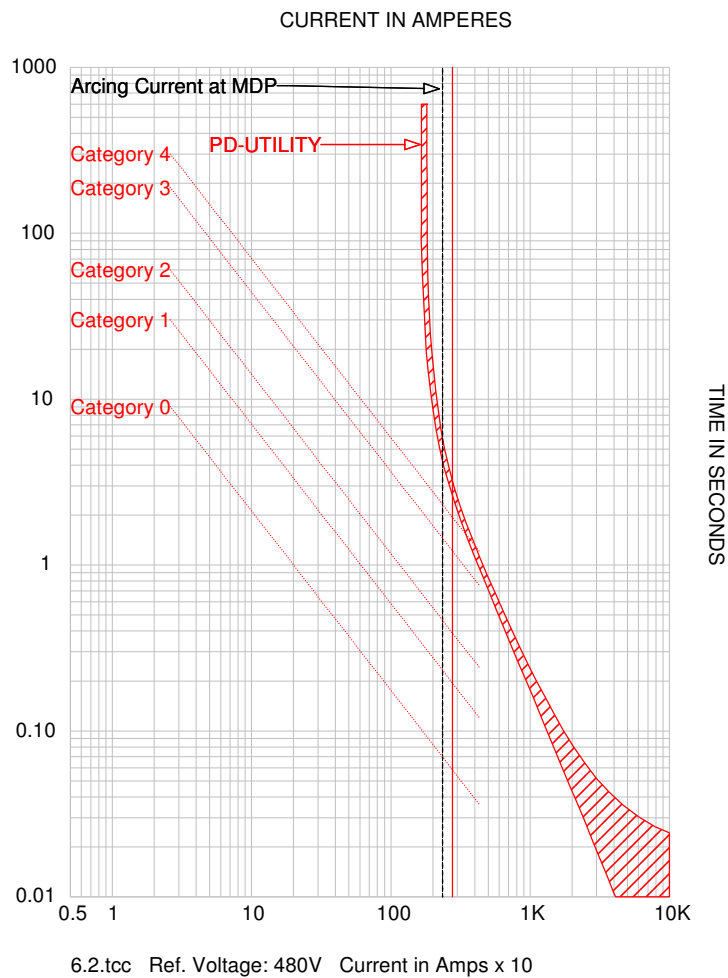

Figure 6.2: TCC Showing Arc Flash Exposure for Six-Hand Rule

This is an unacceptable scenario in a mission critical facility because the incident energy is above 40 cal/cm^2 and, therefore, a hazard risk category of Dangerous. According to NFPA-70E: energized electrical work is not permitted on this device so periodic maintenance or facility changes that include this panel cannot be performed without an electrical shutdown. The feasibility of an electrical shutdown is often not possible in a mission critical facility, thus the system must be designed and constructed differently.

The result of this research is a recommendation that when applying the National Electric Code, Article 230, Part VI, always specify a single main circuit breaker for building shutdown and do not use numerous feeder devices as main disconnects. Furthermore, this single main breaker should be in a separate enclosed device located away from the MDP. This will isolate the protection device of the main panel from the technician working on the panel and therefore lowering the arc flash exposure. If the main breaker is located within the MDP, then there is a dangerous arc flash exposure at the entrance of the service conductors.

The recommendation for minimizing this exposure is to eliminate the implementation of numerous main devices. This can be accomplished by installing a low voltage power circuit breaker ahead of the MDP. This low voltage power circuit breaker should be specified with adjustable settings in the long time, short time, and instantaneous time domains. Adjusting the main breaker settings to mitigate the arc flash will create a safer working environment at the MDP and will allow the facility to be flexible if the fault contribution from the distribution were to change due to generation plant or substation alterations.

After the implementation of this recommended circuit breaker installation, the case study was re-simulated. The one-line diagram showing the computer simulation results is shown in Figure 6.3. The new 1200 amp main circuit breaker is now located ahead of the MDP and is referred to PD-MDP NEW.

At each panel the available fault current, arcing fault, incident energy, and PPE Category are given. The available fault current and arcing current at the MDP remain at approximately the same level. However, with the new main breaker inserted ahead of the

MDP, the result is an incident energy down from 47.6 cal/cm² and Category Dangerous to 2.38 cal/cm² and a Category 1. This is a significant change that would allow technicians to perform energized maintenance on this device.

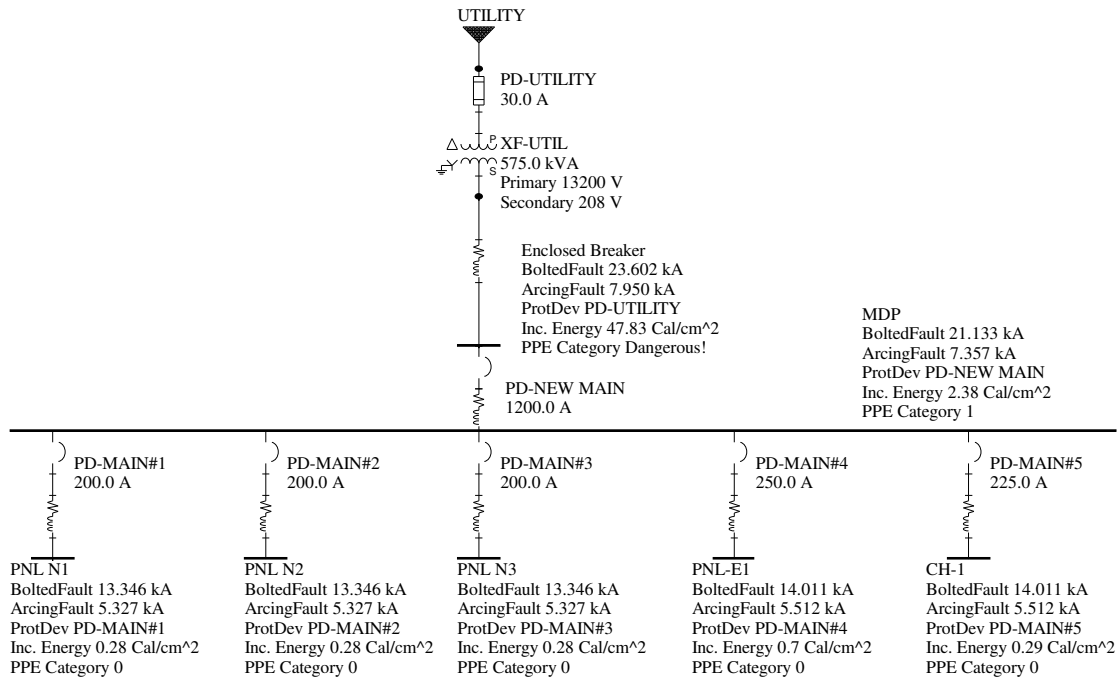

Figure 6.3: Partial One-Line Diagram with Main Breaker Installed

The results of this change can be further validated by analyzing the results in the time versus current domain. The TCC is plotted in Figure 6.4 and it shows the new main device PD-NEW MAIN plotted with the arcing current of 7.35kA. The plot displays the interrupting of the arcing current by PD-NEW MAIN at 0.10 seconds which is in the range of a Category 1 exposure. This allows maintenance to be performed on the MDP while it is energized and the facility remains in normal operation.

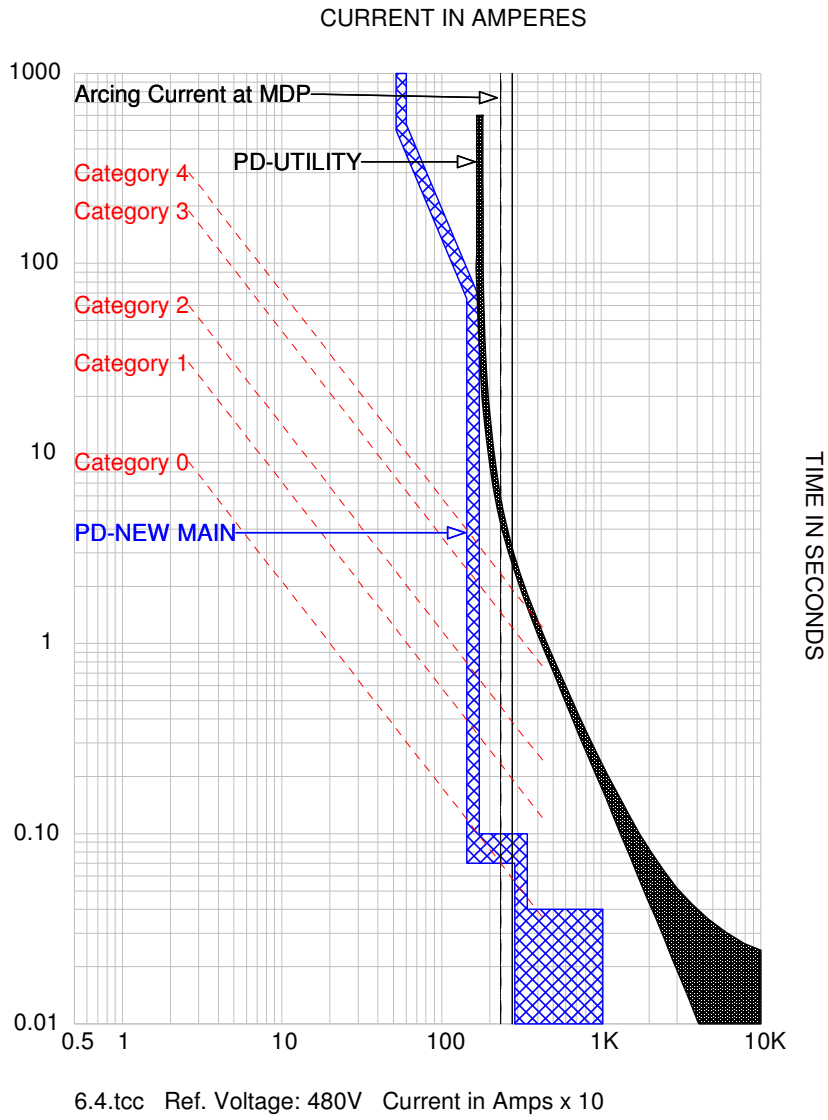

Figure 6.4: TCC with Main Breaker Installed

6.2 At the Electrical Service Entrance the Design Shall Specify Low Voltage Power Circuit Breakers Instead of Fused Disconnect Switches

The National Electrical Code, Article 230, Part IV addresses building main shut down and proper disconnecting methods. Every facility must have a readily accessible means of disconnecting the electrical service. This is often accomplished by installing a main fused disconnect switch at the service entrance typically near the electrical meter. A one-line diagram of this scenario is shown in Figure 6.5.

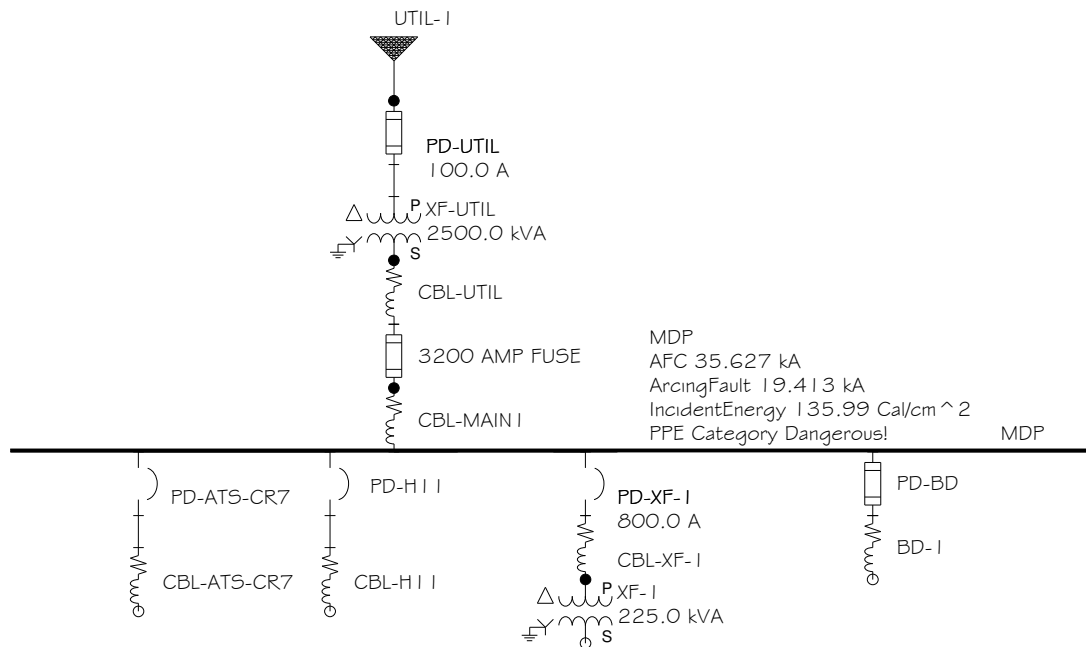

Figure 6.5: One-Line Diagram Showing Main Fused Disconnect

This electrical system consists of a utility 2500kVA transformer serving a main disconnect fused at 3200 amps. The fuse is protecting a main distribution panel MDP which contains three feeder breakers and a fuse. The arc flash hazard for this type of installation can be high or low depending on the available fault current and the resulting arcing current. Figure 6.5 shows an incident energy at the MDP of 136 cal/cm² resulting in a PPE Category of Dangerous. This is unacceptable for a mission critical facility

because the electrical system must remain energized and NFPA 70E does not allow energized work where an arc flash hazard is this extreme.

Analyzing this in the time versus current domain justifies the results of the simulation. Figure 6.6 plots the 3000 amp fuse and the 19.4kA arcing current at the MDP. The fuse curve shows the interruption of the 19.4kA arcing current beyond 2 seconds and resulting in a hazard risk category Dangerous.

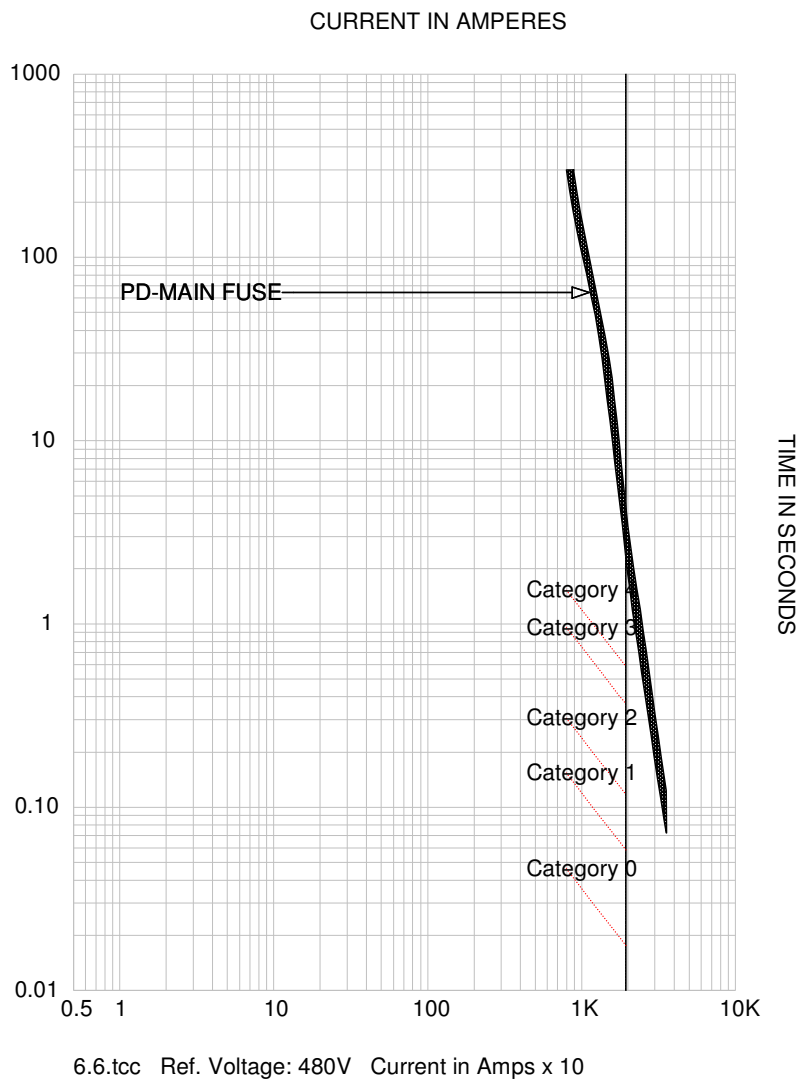

Figure 6.6: TCC for Main Fused Disconnect

The technique developed in this research for minimizing the exposure is to specify a low voltage power circuit breaker with LSI adjustments instead of the fused disconnect switch. This will allow for shaping the protection curve based on the available fault current and arcing current. The one-line diagram showing this system is shown in Figure 6.7. The simulation of the revised circuit shows the arcing current remaining at 19.4kA which is expected. However, the incident energy was decreased to 4.8 cal/cm², resulting in a PPE Category 2.

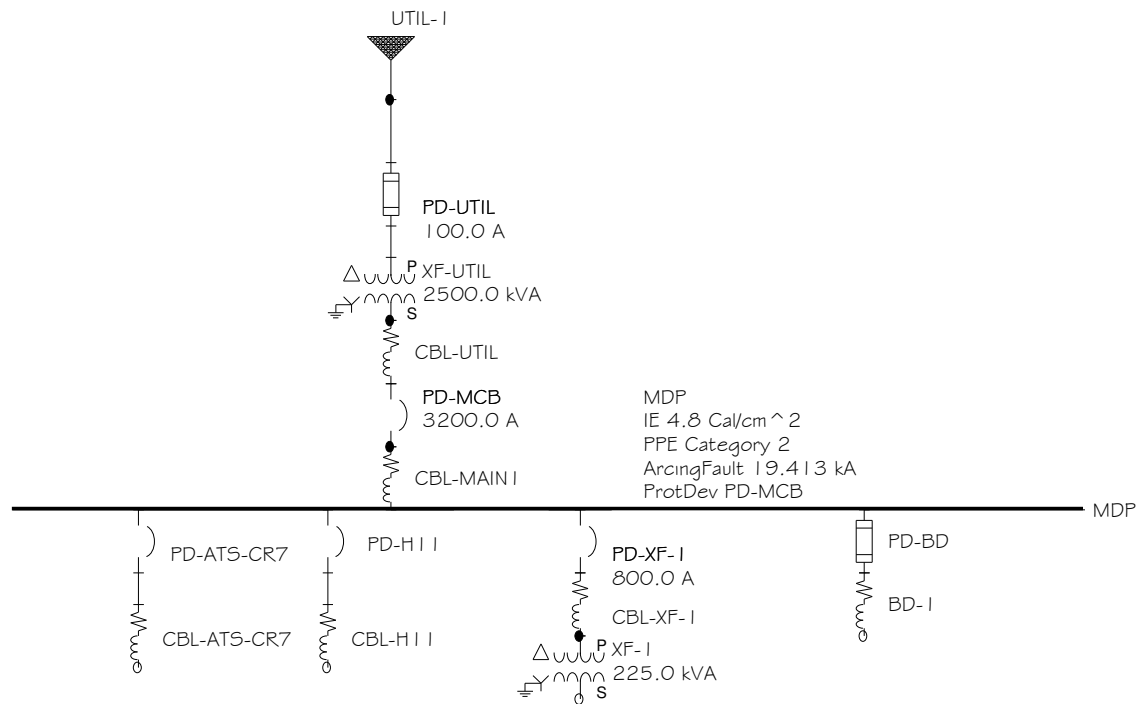

Figure 6.7: Partial One-Line Diagram for Service Entrance with LSI Main Breaker

Analyzing this in the time versus current domain validates the results of the simulation. Figure 6.8 plots the new LSI circuit breaker PD-MCB and the arcing current at the MDP. The breaker curve shows instantaneous interruption of the arcing current at 0.07 seconds and therefore a quicker extinguish of the arc than with the fuse. This is

shown to occur within the hazard risk category 2 range. The simulations result of incident energy at 4.8 cal/cm^2 is consistent with this finding.

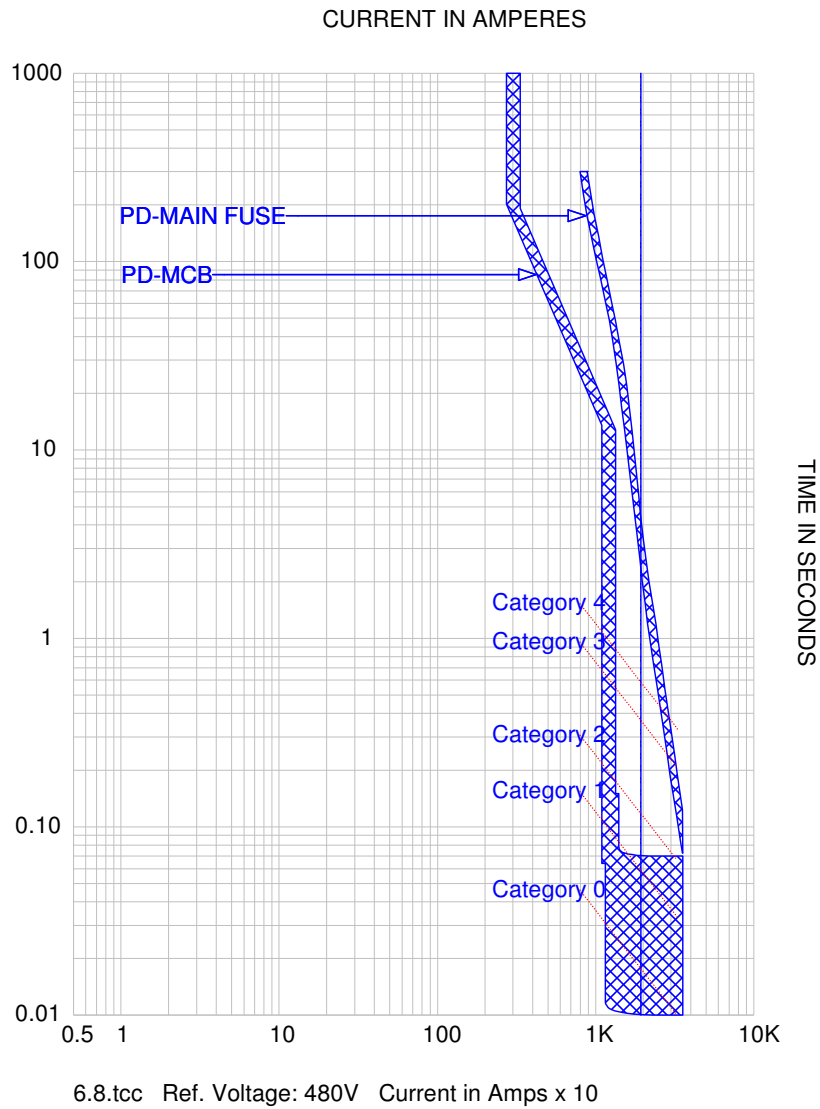

Figure 6.8: TCC for Service Entrance with LSI Main Breaker

6.3 Specify Adjustable Low Voltage Power Circuit Breakers for Protection of Step-Down Transformers Rated above 125kVA

There are several important factors included in the decisions made during the design of the electrical feeders served from the main distribution panel. The feeder conductors and circuit breakers must be sized to carry the calculated amount of current load to avoid an overcurrent situation. The feeder breakers must have proper available interrupting capacity ratings to withstand the fault currents that they must interrupt during a short circuit. The feeder breakers must be properly coordinated with the upstream and downstream protective devices. In mission critical facilities, the transformers and subpanels served by these feeders must be properly maintained and therefore the arc flash hazards at these locations are important.

The service voltage in the facilities being studied is 480 volt, three-phase. However, there are numerous loads in a building that require 120/208 volt service, such as air conditioning equipment, service receptacles, computers, and lighting. This creates a need for the 480 volt service voltage to be transformed down to 120/208 volts. This is accomplished by creating a lower voltage leg in the system by inserting a large step-down transformer fed from the main panel to serve 120/208 volt loads downstream. A one-line diagram of this scenario with a thermal magnetic breaker (PD-XF-1) protecting a 225kVA transformer feeding Panel L1 is shown in Figure 6.9.

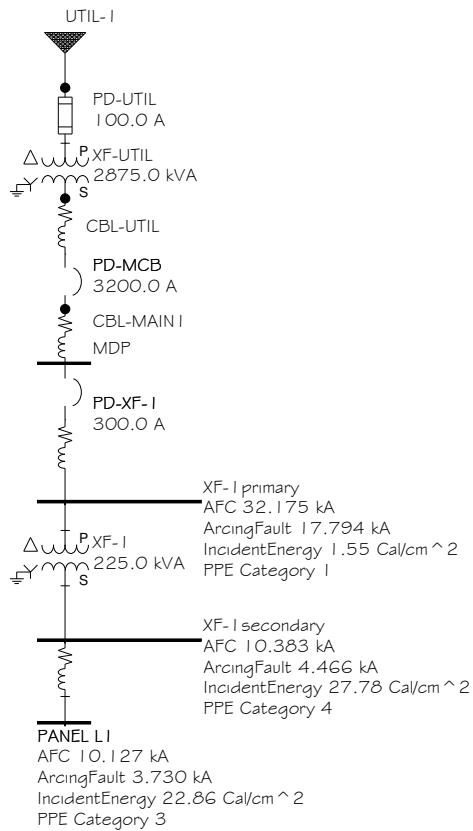

Figure 6.9: Partial One-Line Diagram Showing Arc Flash Increase across 225kVA

The challenge with this scenario is with the decrease in fault current and arcing current that occurs across the transformer. This is expected due to the amount of impedance that the transformer represents in this circuit. The simulation in Figure 6.9 shows the available fault current on the primary side of the 225kVA transformer at 32.17kA and the available fault current at the secondary side at 10.38kA.

Following the equations of IEEE 1584, the fault current has been shown to directly relate to the arcing current. Therefore, the arcing current at the secondary side of the transformer will also decrease considerably when compared to the primary side. The simulation in Figure 6.9 shows the arcing current on the primary side of the 225kVA transformer at 17.79kA and the arcing current at the secondary side at 3.79kA. The

decreased arcing current at the secondary will delay the time for the primary side breaker to interrupt an arc flash.

The amount of time needed to interrupt the arc is directly related to the arc flash incident energy. This leads to an increase in incident energy from 0.6 cal/cm^2 on the primary side of the transformer to 23.3 cal/cm^2 on the secondary side and a PPE category change from 1 to 4. This is a significant increase in the protection equipment required to work on this energized equipment.

Analyzing this in the time versus current domain further validates this outcome. Figure 6.10 displays the TCC plot for the primary side of the transformer. The circuit breaker PD-XF-1 is plotted along with the primary side arcing current of 17.79 kA . It is shown that the circuit breaker interrupts the arc at approximately 0.015 seconds which is in the range of hazard category line 1. The calculations in the simulation calculate this at 1.55 cal/cm^2 .

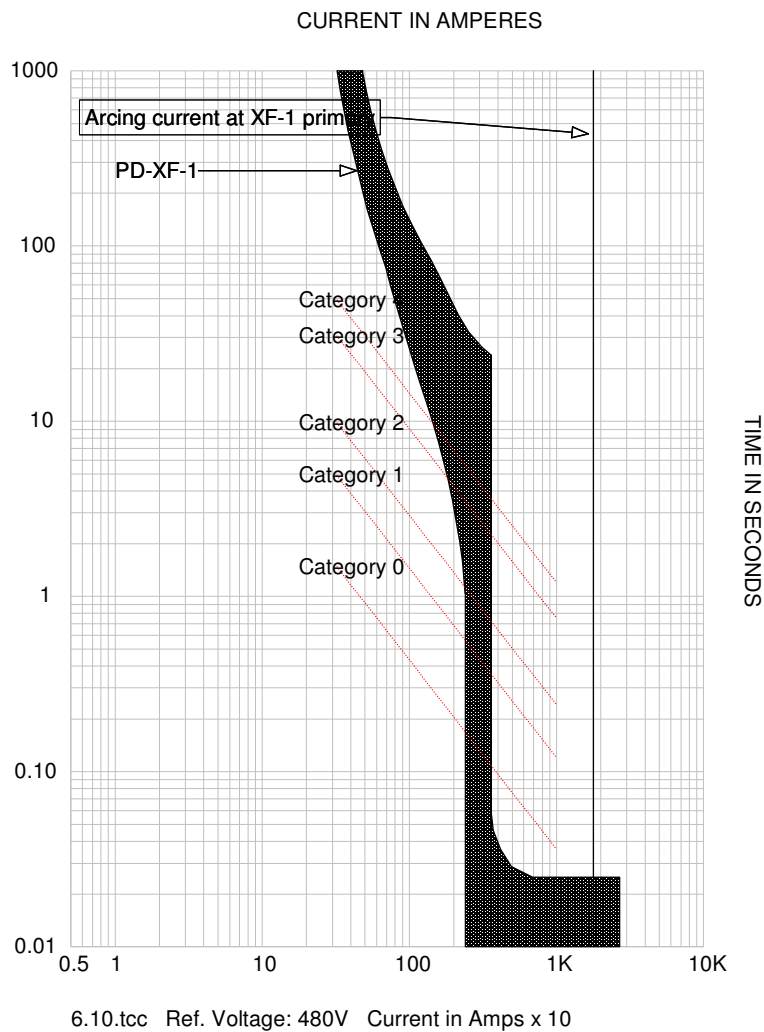

Figure 6.10: TCC Showing Thermal-Mag Breaker and Arcing Current at Primary of XF-1

Figure 6.11 displays the TCC plot for the secondary side of the transformer. The circuit breaker PD-XF-1 is plotted along with the secondary side arcing current of 4.46kA. The plot shows the decrease in fault current and therefore lowering of the arcing current across the transformer XF-1. This moves the arcing current level inside the instantaneous adjustable range of the thermal magnetic breaker, thus causing the long exposure time and high arc flash hazard. It is shown that the circuit breaker interrupts the

arc at approximately 50 seconds, which is above all hazard category lines and therefore considered dangerous for energized work. However, IEEE 1584 limits the maximum exposure time for calculating incident energy at 2 seconds and therefore the calculations in the simulation report this at 27.78kA cal/cm² which corresponds to a hazard risk category 4.

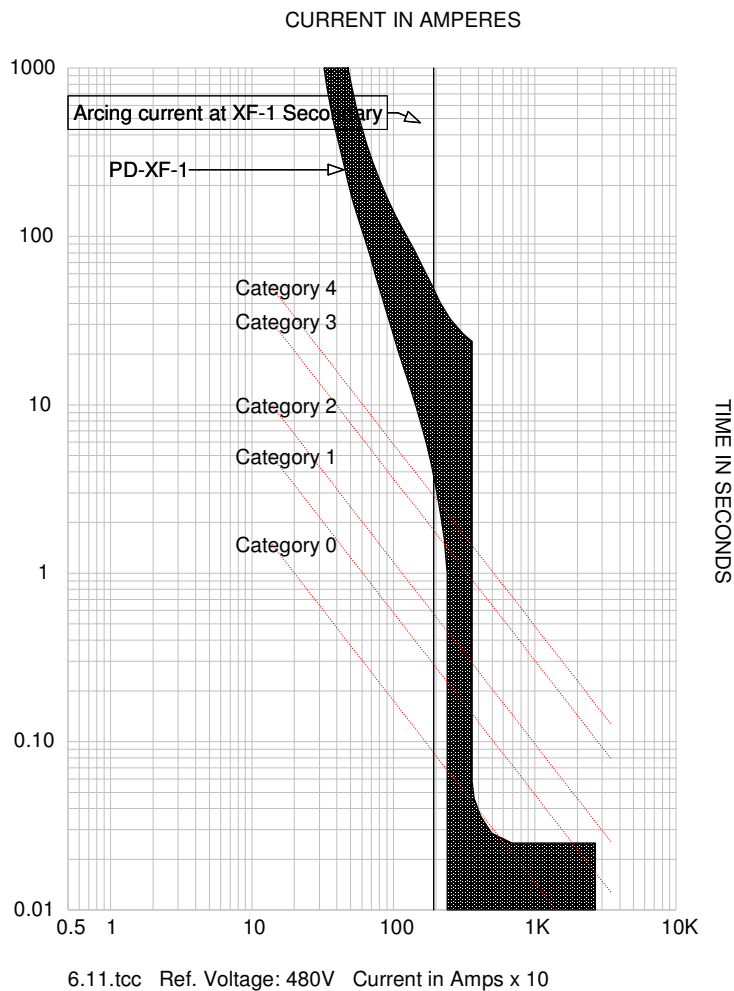

Figure 6.11: TCC Showing Thermal-Mag Breaker and Arcing Current at Secondary of XF-1

Category 4 personal protective equipment is available, but it is preferred to lower the exposure to a category 0 or 1 whenever possible and limit the potential exposure of the technicians. It is the conclusion of this analysis to protect these transformers with a low voltage power circuit breaker containing adjustable LSI adjustments in lieu of the standard thermal magnetic circuit breaker. Although the thermal magnetic breaker has instantaneous adjustment, this change in arcing current is shown to potentially attenuate into the short time region and delay the interrupt time. The low voltage power circuit breakers with LSI are adjustable in the short time and therefore can mitigate this arc flash exposure by interrupting the arc much quicker. The simulation one-line diagram showing this improved system is shown in Figure 6.12.

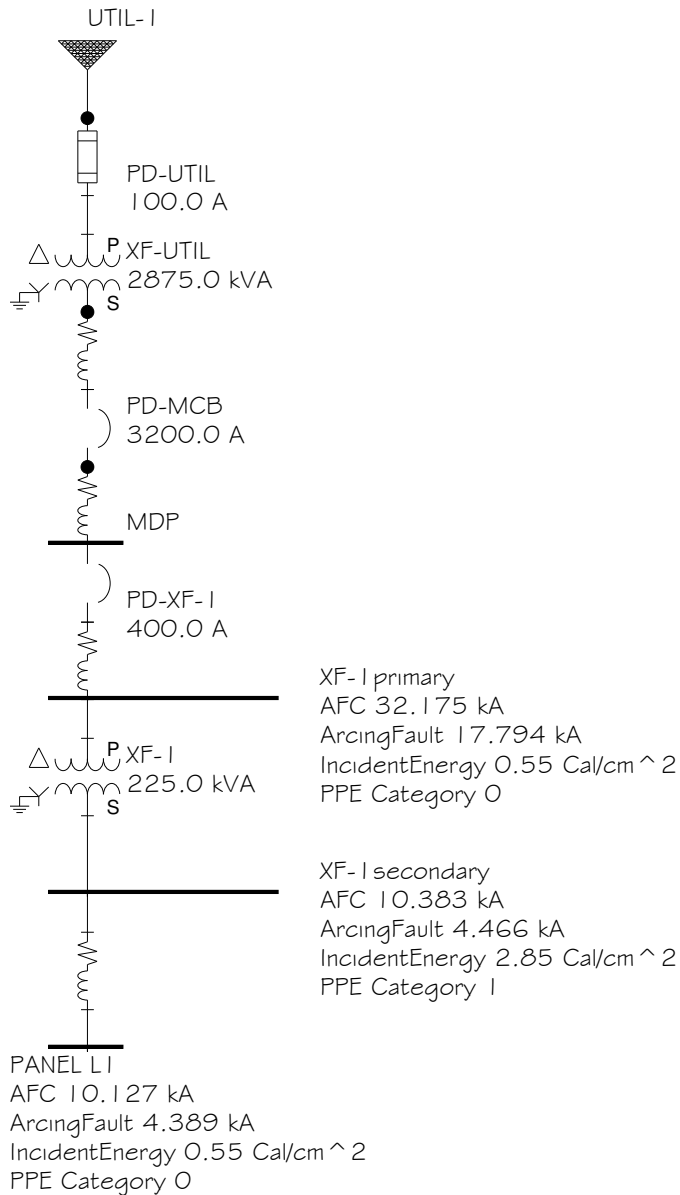
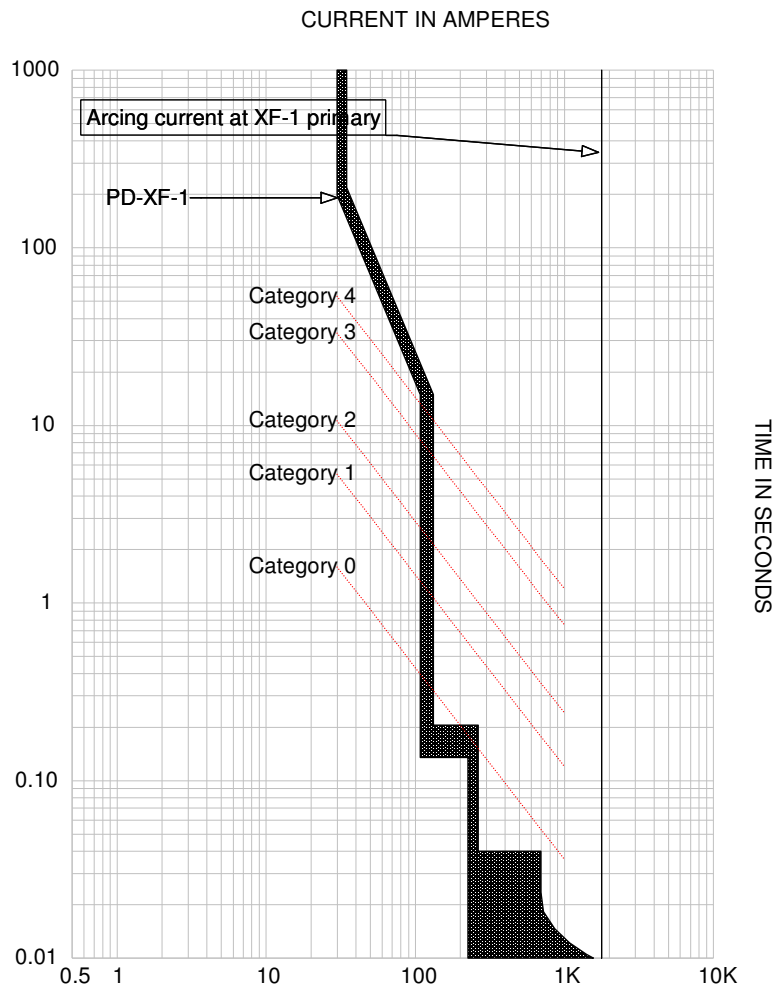

Figure 6.12: Partial One-Line Diagram Showing Arc Flash Mitigation across 225kVA

The simulation for the new system shows that the available fault currents on the primary and secondary of the transformer have not changed. Hence, the arcing currents on the primary and secondary of the transformer have not changed. However, due to the quicker interrupting time of the LSI circuit breaker, the result is lowered incident energy of 0.55 cal/cm² on the primary side of the transformer and 2.85 cal/cm² on the secondary

side. The primary side of the transformer is decreased to a hazard risk category 0 and the secondary side is reduced to a category 1.

Analyzing this in the time versus current domain validates the results of the simulation. Figure 6.13 plots the new LSI circuit breaker PD-XF-1 and the arcing current on the primary side of the transformer. The breaker curve shows instantaneous interruption of the arcing current and therefore a quicker extinguish of the arc than the thermal magnetic breaker. This is shown to occur in the hazard risk category 0 range. The simulation result of incident energy at 0.055 cal/cm^2 is consistent with this finding.



6.13.tcc Ref. Voltage: 480V Current in Amps x 10

Figure 6.13: TCC Showing LSI Breaker and Arcing Current at Primary of XF-1

Figure 6.14 shows the decrease in fault current and therefore lowering of the arcing current across the transformer XF-1. This moves the arcing current level inside the adjustable short-time range of the LSI breaker. Setting the short time inside the arcing current allows for short exposure time and low arc flash hazard. Circuit breaker PD-XF-1 is shown to interrupt the arcing current at approximately 0.21 seconds and therefore low incident energy is calculated and a PPE Category 1 is calculated on the secondary of the

transformer. This is consistent with the simulation incident energy calculation resulting in 2.85cal/cm^2 .

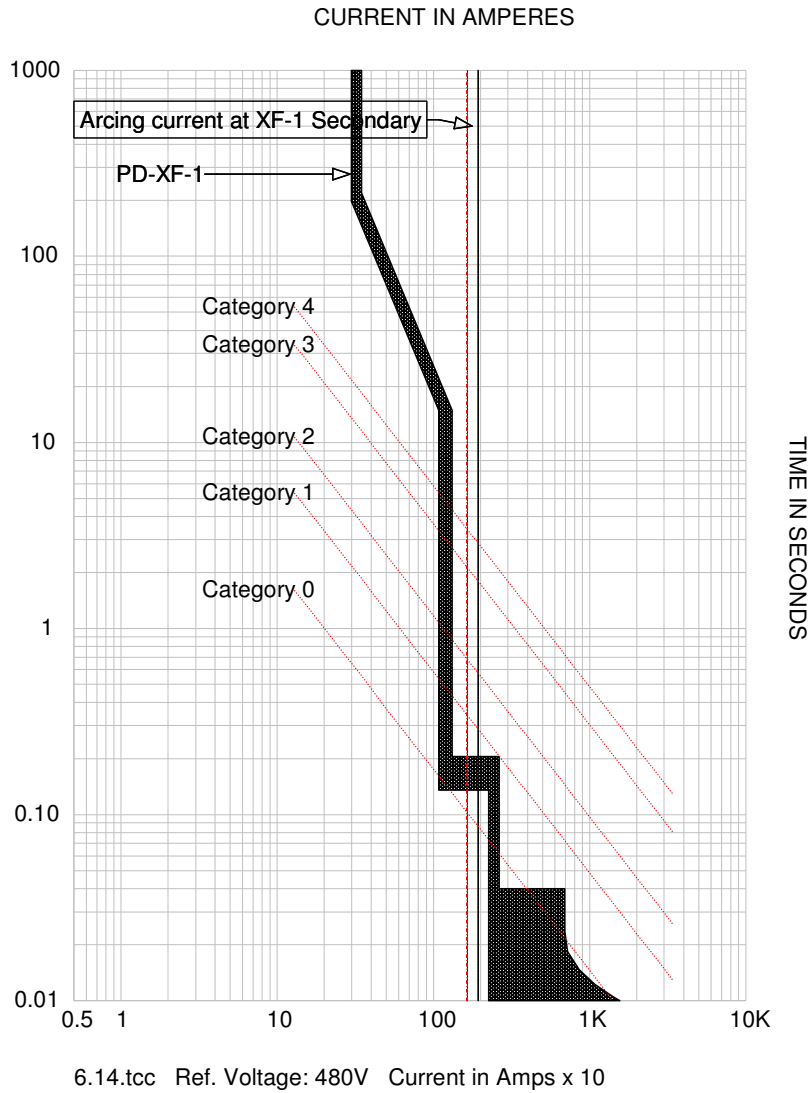

6.14.tcc Ref. Voltage: 480V Current in Amps x 10
Figure 6.14: TCC Showing LSI Breaker and Arcing Current at Secondary of XF-1

6.4 Step-Down Transformers Larger than 125kVA Shall Be Replaced with a Design Having Two Smaller Transformers

The service voltage in the facility we are studying is 480/277 volt, three-phase. However, there are numerous loads in a building that require 120 volt service such as basic receptacles, computers, and lighting. This requires the 480 volt service voltage to be transformed down to 120 volts. This is typically accomplished by creating a lower voltage leg in the system by inserting a large step-down transformer in the system and feeding all 120/208 volt loads downstream. When the 120/208 volt load is significant, the step down transformer can be 150kVA and larger. A one-line diagram of this scenario with a 225kVA transformer feeding Panel L1 is shown in Figure 6.15.

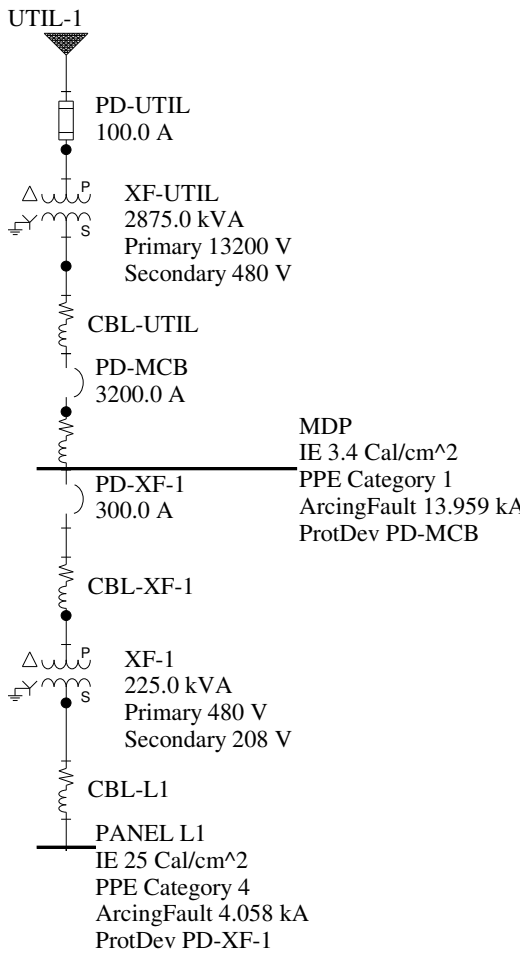

Figure 6.15: Partial One-Line Diagram with 225kVA Step-Down Transformer

The computer simulation of the circuit described in Figure 6.15 shows an incident energy of 25 cal/cm² and a PPE Category 4.

The TCC for this configuration is plotted in Figure 6.16 and this shows the circuit breaker (PD-XF-1) interrupting the arcing current beyond 2 seconds thus confirming the high exposure.

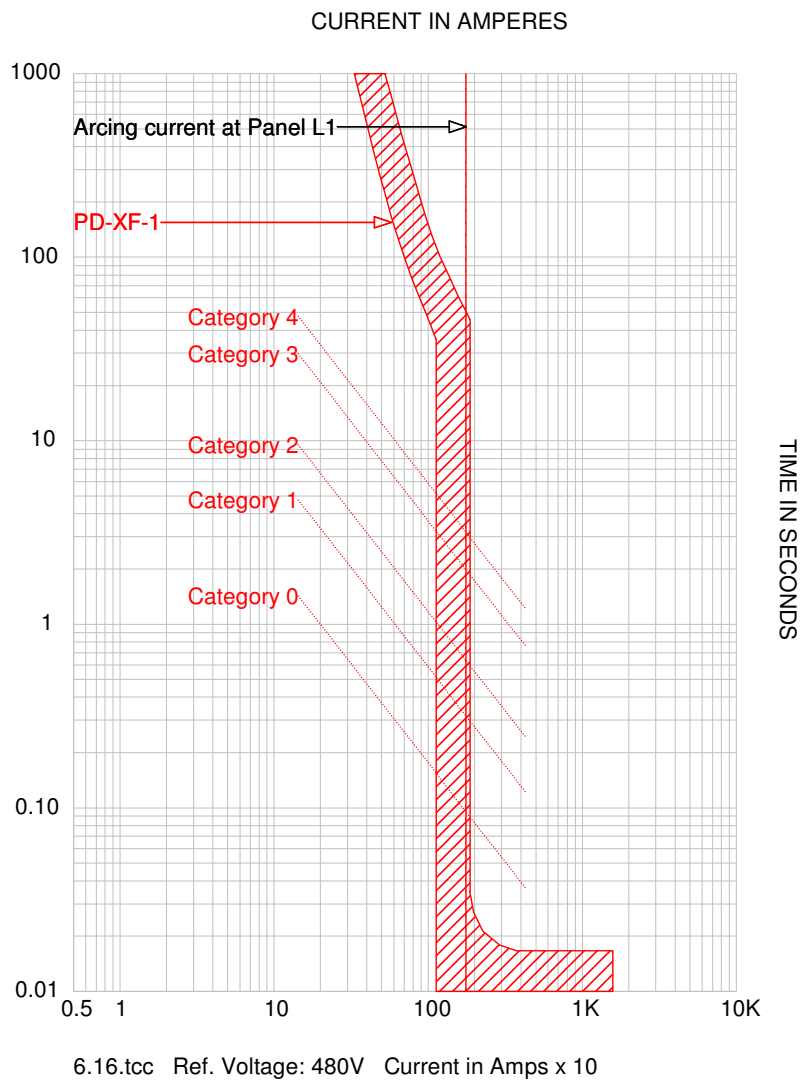

Figure 6.16: TCC Showing Arc Flash Hazard at Panel L1

The recommendation for minimizing this exposure is to replace one large step down transformer with multiple smaller transformers that are less than 125kVA. The increased impedance of the smaller conductors and transformers brings down the fault current and arcing current. The smaller rated circuit breaker has the ability to stay below this arcing value. This also allows for application of NFPA 70E option of reporting Category 0 for any bus served by a transformer less than 125kVA and 240 volts. The one-line diagram showing this system is shown in Figure 6.17. The 225kVA transformer feeding Panel L1 is replaced by two 112.5kVA transformers feeding Panels L1 and L2. The result is an incident energy of 0.2 cal/cm² and a Category 0.

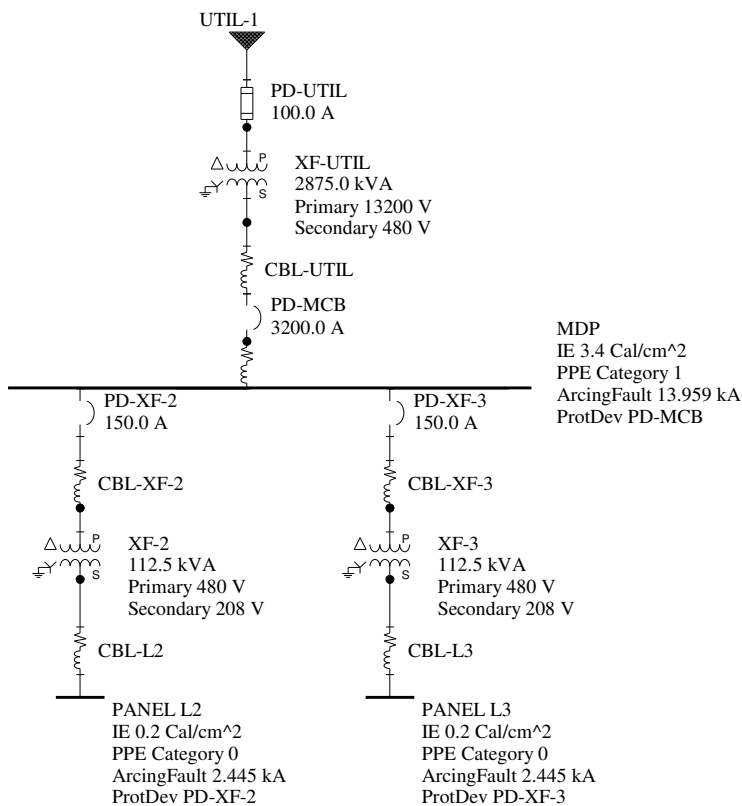

Figure 6.17: Partial One-Line Diagram Showing Two 112.5kVA Transformers

The TCC for this configuration is plotted in Figure 6.18 and this shows the circuit breaker (PD-XF-2) interrupting the arcing current at 0.027 seconds therefore reducing the incident and PPE Category.

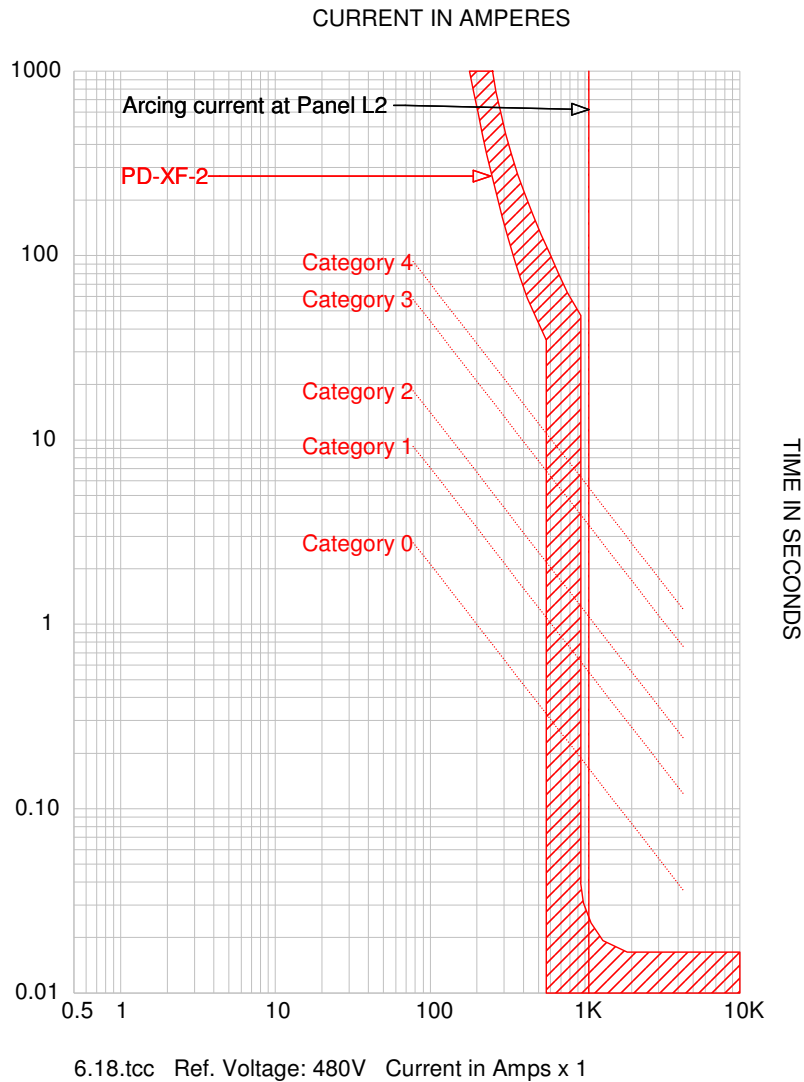

Figure 6.18: TCC Showing Arc Flash Hazard at Panel L2

This chapter has focused on the introduction and implementation design techniques developed during this dissertation research intended to mitigate the arc flash hazard at specific locations in a 480 volt electrical distribution system. The four techniques were described and simulated in locations of an electrical system where a high arc flash hazard is typically present due to inherent properties of the system design. When applied as shown, these methods resulted in the ability to considerably decrease the arc flash hazard. While planning mission critical facilities, electrical design engineers can develop systems with lower arc flash hazards by implementing these techniques.

7. CONCLUSIONS AND FUTURE WORK

This work has been focused on techniques for mitigating arc flash hazard exposure in 600 volt and below electrical systems. The methodologies for fault current calculations, protective device coordination, and arc flash hazard analysis have been presented. Several of the mainstream arc flash mitigation products and techniques have been described. Case studies of existing facility arc flash studies have been presented along with the applied mitigation solutions. The theory of instituting design techniques with the goal of mitigating the arc flash hazard was developed and tested.

7.1 Conclusions

The impact of using four design techniques to decrease the arc flash hazard at specific locations in an electrical distribution system has been examined.

1. When applying the National Electric Code, Article 230, Part VI, always specify a single main circuit breaker for building shutdown.

The first design technique is applied at the electrical service entrance and is aimed at lowering the arc flash hazard at the main distribution panel. The simulation showed that when multiple electrical disconnects are used as permitted by NEC, Article 230, Part VI, the arc flash hazard can be extremely high. When designing the system with one main circuit breaker the main distribution panel has an interrupting device to limit the exposure of an arc flash.

The implementation of this design technique for this particular case decreased the arc flash incident energy from 47.6cal/cm^2 to 0.95cal/cm^2 . This changed the PPE category from a Dangerous level down to a category 0. This allows a qualified technician to perform maintenance on this device with minimal arc-flash exposure.

2. At the electrical service entrance the design shall specify enclosed low voltage power circuit breakers in place of fused disconnects.

The second design technique is applied at the electrical service entrance and is also aimed at lowering the arc flash hazard at the main distribution panel. The simulation showed that sometimes when fused disconnects are used as permitted by NEC, Article 230, Part VI, the arc flash hazard can be extremely high at the main distribution panel. When designing the system with a low voltage power circuit breaker with LSI adjustments as the main circuit breaker the exposure of an arc flash is limited.

The implementation of this design technique for the particular case analyzed decreased the arc flash incident energy from 136cal/cm^2 to 4.8cal/cm^2 . This changed the PPE category from a Dangerous level down to a category 2. This allows a qualified technician to perform maintenance on this device with minimal arc-flash exposure.

3. Specify adjustable low voltage power circuit Breakers for protection of step-down transformers rated above 125kVA.

The third design technique is applied at a feeder circuit from the main distribution panel that is serving a step down transformer. The simulation showed that when a transformer larger than 125kVA is protected by a thermal magnetic breaker, the secondary side arc flash hazard can be extremely high. When designing the feeder with a

low voltage power circuit breaker with LSI adjustments the arc flash exposure can be mitigated to a safer level.

The implementation of this design technique for this particular case decreased the arc flash incident energy from 23.3cal/cm^2 to 0.6cal/cm^2 . This changed the PPE category from a category 3 level down to a category 0. This allows a qualified technician to perform maintenance on this device with minimal arc flash exposure.

4. Step-Down Transformers larger than 125kVA shall be replaced with a design having two smaller kVA transformers.

The fourth design technique is applied at a feeder circuit from the main distribution panel that is serving a step down transformer. The simulation showed that when a transformer larger than 125kVA is protected by a thermal magnetic breaker the secondary side arc flash hazard can be extremely high. When designing the feeder with two smaller circuits with reduced kVA transformers the arc flash hazard is reduced significantly.

The implementation of this design technique for this particular case studied decreased the arc flash incident energy from 25.0cal/cm^2 to 0.2cal/cm^2 . This changed the PPE category from a category 4 level down to a category 0. This allows a qualified technician to perform maintenance on this device with minimal arc-flash exposure.

In all four cases the implementation of the recommended design technique has shown a significant decrease in the incident energy and hazard risk category. Table 7.1 displays the cumulative results of all four methods for each particular case and summarizes the decrease of the arc flash hazard.

Table 7.1 Before and After Arc Flash Hazard

Method #	Before Incident Energy (cal/cm²)	Before Category	After Incident Energy (cal/cm²)	After Category
1	47.6	Dangerous	0.95	0
2	23.3	3	0.6	0
3	136	Dangerous	4.8	2
4	25	4	0.2	0

7.2 Further Work

The application of these design techniques are based on the interpretation of the most current publications of NFPA-70E and IEEE-1584 and should be applied within that framework. There is a continued joint research effort by NFPA and IEEE to further the understanding of arc flash hazards. As this research is performed, new codes and standards are likely to be released in the future. The design techniques described in this work should be verified under any new releases of codes and standards.

The design techniques described in this dissertation should be offered for continuing education to design engineers. If these methods become a part of the design process then the constructed electrical systems will have more flexibility to control arc flash hazards.

REFERENCES

- [1] Jim Phillips, P.E., “The History of Arc Flash and Electrical Safety” May 2009, *Electrical Contractor Magazine*.
- [2] Charles F. Dalziel, “The Effects of Electric Shock on Man” 1956
- [3] Jim Phillips, P.E., “Fitting the Puzzle Pieces Together to Provide Electrical Safety” *NEC Digest*, February 2005.
- [4] Ralph Lee, “The Other Electrical Hazard: Electric Arc Blast Burns,” *IEEE Trans. Industrial Applications*, Vol. 1A-18, No. 3, p246, May/June 1982.
- [5] Richard L. Doughty, Dr. Thomas E. Neal, H Landis Floyd, “Predicting Incident Energy to Better Manage The Electric Arc Hazard on 600 V Power Distribution Systems,” *IEEE*, Paper No. PCIC-96-36, 1998.
- [6] *IEEE Guide for Arc Flash Hazard Calculations*, IEEE Standard 1584-2002.
- [7] Finley Ledbetter, Scott Peterson, “Arc Flash Mitigation – Distance is Safety,” Group CBS Inc. Technical Paper 2004.
- [8] Thomas E. Neal, Allen H. Bingham, Richard L. Doughty, “Protective Clothing Guidelines for Electric Arc Exposure,” *IEEE Trans.* Vol. 33, No. 4 July/August 1997.
- [9] Thomas E. Neal, Allen H. Bingham, Richard L. Doughty, Terrence A. Dear, “Testing Update on Protective Clothing & Equipment for Electric Arc Exposure,” *IEEE Paper* No. PCIC-97-35..
- [10] *NFPA 70E, Standard for Electrical Safety in the Workplace*, 2004 Edition.
- [11] Keith Lane, P.E., “Beware of Simplistic Fault Current Calculations” September 2001, *Electrical Contractor Magazine*.
- [12] Baldwin Bridger, P.E. “X/R Ratio” Tech Brief, *NETA WORLD*, Winter 2009-2010.
- [13] J. Duncan Glover & Mulukutula S. Sarma, *Power System Analysis and Design*, Brooks/Cole 2001.

- [14] Baldwin Bridger, P.E. “Short Circuit Currents” Tech Brief, NETA WORLD, Winter 2009-2010.
- [15] IEEE Recommended Practice for Protection and Coordination of Industrial and Commercial Power Systems, IEEE std. 242-2001(Buff Book).
- [16] Ralph E. Fehr III, *Industrial power Distribution*, Prentice Hall Inc., New Jersey, 2002
- [17] 2005 National Electric Code, National Fire Protection Association, pp. 27.
- [18] Ed Larson, Jim Degnan, “Selective Coordination in low-Voltage Power Distribution Systems: Is the Level Important?” IEEE/IAS Industrial and Commercial power Systems Technical Conference, May 2008.
- [19] L. Kumpulainen, S. Dahl, J. Ma, “Mitigation of Arc-Flash Hazards and Reduction of Coasts be Selective Arc-Flash Protection” CISED 2008 China Internal Conference on Electricity Distribution, December 2008.
- [20] M. Murphy, “How to Form a Bounding Arc Flash Study for Your Site” IEEE/IAS Electrical Safety Workshop, Dallas, Texas, March 18-21, 2008.
- [21] D M. Doan, “Designing a Site Electrical System with Arc Flash Energy under 20 cal/cm²” IEEE/IAS Electrical Safety Workshop, Dallas, Texas, March 18-21, 2008..
- [22] William A. Brown, Ron Shapiro “A Comparison of Arc Flash Incident Energy Reduction Techniques Using Low Voltage Power Circuit Breakers” IEEE/IAS Industrial and Commercial power Systems Technical Conference, August 2006.
- [23] Christopher Inshaw, Robert A. Wilson, “Arc Flash Hazard Analysis and Mitigation”.
- [24] H. Wallace Tinsley III, Michael Hodder, Aidan M. Graham, “Beyond the Calculations: Life After Arc Flash Analysis”.
- [25] Catherine Irwin, Udo Kerssebaum, Helmut Eichinger, Daniel Doan, “Mitigating Personnel Exposure to the Arc Flash Hazard”.
- [26] Robert A. Wilson, Rainer Harju, Juha Keisala, Sethuraman Ganesan “Tripping With The Speed of light: Arc Flash Protection”..
- [27] Daniel R. Doan, Jennifer Slivka, Chris Bohrer, “A Summary of Arc Flash Hazard Assessments and Safety Improvements”.
- [28] G.E. Heberlein Jr., J.A. Higgins, and R.A. Epperly, ‘Report on Enclosure Internal Arc Tests’, IEEE Industry Applications Magazine, Vol 2, Issue 3, May/June 1996, pp 35-42.

- [29] IEEE Standard C37.20, Standard for Metal Enclosed Low Voltage Power Circuit Breaker Switchgear.
- [30] ABB Corporation, “Arc Protection Technical Aspects” January 2005.
- [31] ABB Corporation Buyers Guide, REA 10_Arc Protection Relay, 1MRS750929-MBG, May 1999.
- [32] ABB Corporation Instruction Booklet, MSOC Relay, IB 7.2.1.7-16 Issue D, June 2000.
- [33] Thomas A. Domitrovich, Adrian M. Graham, Charles J Nochumson “Selective Coordination versus Arc Flash – The Great Debate”, IEEE/IAS Electrical Safety Workshop, St. Louis, MO, February 2-6, 2009.
- [34] “NFPA 70 National Electrical Code Handbook”, National Fire Protection Association, 1996.
- [35] 2008 National Electric Code, National Fire Protection Association.
- [36] Roger C. Dugan, Mark F. McGranahan, Surya Santoso, H. Wayne Beaty, *Electrical Power Systems Quality*, McGraw Hill 2002.
- [37] Richard C. Dorf, *The Electrical Engineering Handbook*, CRC Press 1993.
- [38] James J. Burke, *Power Distribution Engineering, Fundamentals and Applications*, Marcel Dekker, Inc. 1994.
- [39] David D. Roybal, P.E. “Circuit Breaker Interrupting Capacity and Short-Time Current Ratings” IEEE Industry Applications Magazine, July/August 2005.
- [40] UL489-2002, *Molded Case Circuit Breakers and Circuit Breaker Enclosures*, Northbrook, IL: UL.
- [41] ANSI/IEEE C37.13-1997, *IEEE Standard for Low-Voltage AC Power Circuit Breakers Used in Enclosures*, Northbrook, IL: UL.
- [42] IEEE Recommended Practice for Applying Low-Voltage Circuit Breakers used in Industrial and Commercial Power Systems, IEEE Std. 1015-2005 (IEE Blue Book) Recognized as an American National Standard (ANSI).
- [43] Clive W. Kimblin, William Long, “Low-Voltage Power Circuit Breakers and Molded Case Circuit Breakers – A Comparison of Test Requirements” IEEE Industrial and Commercial Power Systems Technical Conference, 1999.

- [44] UL Standard for Safety for Low-Voltage AC and DC Power Circuit Breakers Used in Enclosures, UL 1066, Third Edition, May 30, 1997.
- [45] ANSI C37.16-1997, Low-Voltage Power Circuit Breakers and AC Power Circuit Protectors – Preferred Ratings, Related Requirements and Applications Recommendations.
- [46] ANSI C37.50-1989, Low –Voltage AC Power Circuit Breaker used in Enclosures- Test Procedures.
- [47] P.G. Newberry, “Fuse Technology – Progress to Date” Electronica and Power Magazine, February 1976.
- [48] Energy Information administration historical electrical data: ww.eia.doe.gov.
- [49] IEEE Recommended Practice for Electrical Power Distribution for Industrial plants, IEEE std. 141-2001(Red Book).
- [50] IEEE Recommended Practice for Grounding of Industrial and Commercial Power Systems, IEEE std. 142-2001(Green Book).
- [51] John Merrell, “The Importance of the X/R Ratio in Low-Voltage Short Circuit Studies. ww.powerstudies.com, 1999.
- [52] GE Electrical Distribution & Control Low-Voltage Protector Application Seminar, August 1999.